

ARIES MK6900/MK7900/MK8900 “Crusader”



u s e r ' s g u i d e

Important Export Restrictions! Commodities, products, technologies and services contained in this manual are subject to one or more of the export control laws and regulations of the U.S. Government and they fall under the control jurisdiction of either the US Department of State or the US BIS-Department of Commerce. It is unlawful and strictly prohibited to export, or attempt to export or otherwise transfer or sell any hardware or technical data or furnish any service to any foreign person, whether abroad or in the United States, for which a license or written approval of the U.S. Government is required, without first obtaining the required license or written approval from the Department of the U.S. Government having jurisdiction. Diversion contrary to U.S. law is prohibited.



**AMERICAN
TECHNOLOGIES
NETWORK
CORP.**

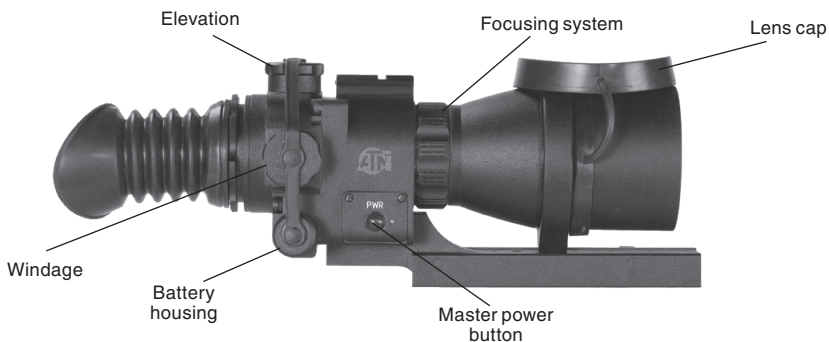
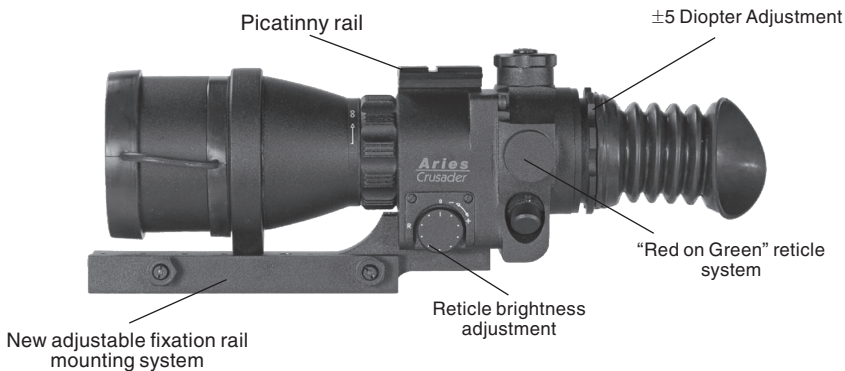

DIGITAL INFRA-RED ILLUMINATOR

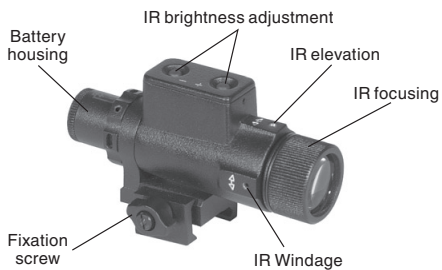

FREE ADD-ON FOR YOUR ARIES SCOPE



CAUTION:

THIS PRODUCT CONTAINS NATURAL RUBBER LATEX WHICH MAY CAUSE ALLERGIC REACTIONS.

The information in this manual furnished for information use only, is subject to change without notice, is not to be construed as a commitment by ATN Corp.

ATN Corp. assumes no responsibility or liability for any errors or inaccuracies that may appear in this book.

©2008 ATN Corp. All right reserved.

APPLICATION

Do you want the best NVD weapon sight on the market? If so then our new **Aries MK6900/MK7900/MK8900 “Crusader”** is for you. It doesn't get any better than the Crusader when it comes to performance. For the Crusader we use a top of the line “Prime Select” light intensifier tube for added light gain and resolution. Combine this select tube with 5x magnification and a super fast F:1.4 lens the image that you will get out of your Crusader is unbelievable.

The best optics, tubes and 2 year warranty makes the Aries MK6900/MK7900/MK8900 Crusader one of the best Night Vision weapon sights there is!

FEATURES

- Top-notch performance with pro-oriented design
- 5X magnification, F:1.4, f90mm lens
- “Red on Green” reticle system with 1/8 inch @ 100 yards adjustment
- New adjustable fixation rail mounting system
- Prime Select 2nd Gen. (MK6900), Prime Select 3rd Gen. (MK7900) or 4th Gen. (MK8900) tubes used
- Automatic brightness control(ABC) for tube protection

SPECIFICATIONS

Generation.....	2nd+ (MK6900) 3rd (MK7900) and 4th (MK8900)
Magnification	5X
Objective:	F:1.4, f90mm lens
FOV	12 deg.
Reticle	Red On Green
Windage & elevation adjustments	1/8MOA
IR illuminator	Super 450mw
Diopter adjustment	+/-5
Battery Life	60 hours (MK6900) 50 hours (MK7900 and MK8900)
Operating Temperature.....	-40°C to +50°C
Storage Temperature.....	-50°C to +70°C
Dimensions	240mm x 90mm x 110mm/9,5” x 4,3” x 3,5”
Weight	1.55kg/3,4 lbs

* ATN reserves the right to change the above specifications at any time without notice

PREPARATION FOR OPERATION

Before getting started make sure to follow these steps:

- Install the battery into its housing with the polarity order shown on the main body of the unit.
- Switch on the Aries scope with the protective lens cover still attached to the lens.
- Make sure that the green luminance of the light intensifier tube is present.
- Observe the scene, and adjust the diopter and/or lens for optimal image clarity.
- You may now enter a dark environment or simply shut the lights off in order to darken the room.
- Next, remove the lens cap/daylight filter.
- Observe the scene, and adjust the front lens for ideal focus.



- Finally, you may want to turn the infra red (IR) illuminator on. Notice the ability of the Aries scope to see in total darkness with the aid of the IR illuminator.

OPERATING

MOUNTING

1. Slightly loosen the fixing screws on the 7/8" weaver rail built into the scope.
2. Place the scope on the dovetail mount of the fire arm making certain that the mount aligns with the receptor attachment screw groove. Adjust as necessary.
3. Tighten the horizontal fixing screws.

NOTE: Receptor attachment screws may need to be tightened after continuous shooting.

MOUNTING SYSTEM

The ATN Night Vision Riflescopes Mounting System allows to change the position of the riflescope flexibly on the weapon in relation to a shooter in combination with the fixed positions already available on the weaver rail. For this purpose in the base of the mounting bracket there is a rail with a fixing projection. There are three grooves in the mounting bracket for mounting this rail. Besides it is possible to change the position of the riflescope additionally by 1/3 of inch. For doing this one needs to about-face the rail.

To change the position of the riflescope on the weaver rail additionally follow the steps mentioned below:

1. Unscrew the two screws, which attach the rail to the mounting bracket.
2. Take the rail out of the groove.
3. About-face the rail in case of necessity.
4. Place the rail into another groove.
5. Fix the rail with the two screws.

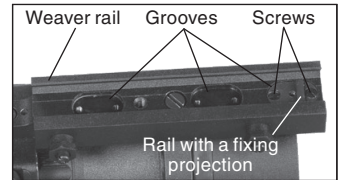

NOTE: If the rail is not taken out easily, screw up tight one of screws into the threaded aperture in the middle of a fixing projection of the rail. Continue rotation of the screw. Thus the screw will push out a rail from a groove.

BRIGHTNESS ADJUSTMENT

By rotating the "R" handle you may adjust the reticle's brightness. Adjustment could be easily seen if you look through the scope while adjustment.

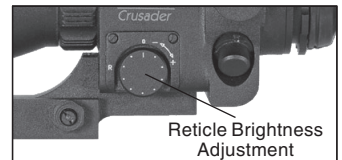

WINDAGE AND ELEVATION

The vertical and horizontal adjustments for the Aries can be achieved by turning the elevation and windage adjustment mechanisms (remove dust caps first). Each click equals to 1/8 inches at 100 yards. When reaching the maximum of rotation do not use force.



FOCUSING

To focus your riflescope you will need to adjust the diopter first thing. Simply turn the diopter clockwise until it stops. Then, while looking through the diopter at a subject, slowly turn the diopter back counter clockwise until the grain in the image is sharp.

NOTE: We suggest that you focus the diopter during daylight with the filter on.

Next, focus the front lens until the image and the grain are both sharp. When you are in the low-light conditions and the daylight filter is off you may focus the front lens to receive a sharp image, the diopter should not be adjusted.

NOTE: The front lens should be readjusted as you view objects at different distances.

IR ILLUMINATOR

Infra-red (IR) Illuminators are common for night vision technology. The IR light greatly enhances the performance of your scope, while remaining almost totally invisible to the naked eye. In dark environment, power up the scope. Now, find a scene and examine it without the IR on then with IR powered up. Note the difference in illumination. It is important to remember that the IR illuminator is simply an infra red light source, and like any light source it may lose its effectiveness over a great distance.

For installation of the IR illuminator onto the rifle-scope use the picatinny rail of the scope.

The IR illuminator control buttons are located on its side. To switch the Digital IR illuminator on/off press “+” and “-” buttons simultaneously. When the IR illuminator is switched on you can see the green LED lit. By pushing the buttons “+” and “-” you may adjust the IR brightness.

The IR beam is focusable to change the field of coverage. To change the beam width slightly turn the IR lens.

You could change the IR control panel fitting your needs. The wrench included into the set should be used for weakening the fixing nut located on the IR. Rotate the IR placing at in the most convenient position. Tighten the nut with the wrench to fix the new position.

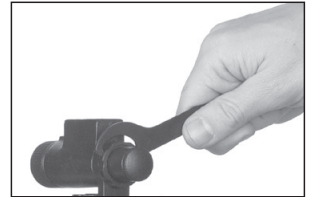
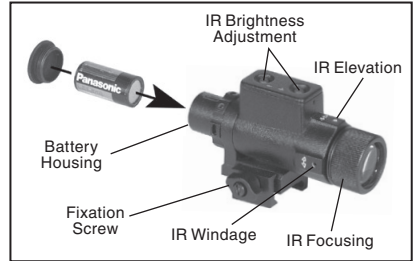

RANGEFINDER RETICLE

A 6' target fits between the short baselines and the numbered main horizontal line. If the 6' target fits between the 2nd short baseline and the main line the target is 200 yards away. If the same target fits between the 4th short baseline and the main line the target is 400 yards away. The target would be either 100, 300 and 500 yards away.

The vertical lines in chevron reticle are proportioned to help in rangefinding and in making allowances for wind or movement.

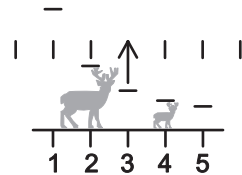

If a 6' target fits between these two lines then the target is 200 yards away.

If a 6' target fits between these two lines then the target is 400 yards away.

CLEANING THE EYEPIECE

You may need to clean the eyepiece of the riflescope from time to time in order to guarantee top performance. When you receive your riflescope you should check for dust on the eyepiece of the unit.

First you will need to remove the eyepiece. To do that you will need to initially loosen the 2 set screws that can be found on the base. Then unscrew the eyepiece counter-clockwise to remove it.

NOTE: You do not have to remove the set screws completely, they are very small and easy to misplace.

CAUTION: Use only Photographic lens cleaning tissue on these surfaces. Be careful not to scratch or smudge any of these surfaces. When using compressed air to blow dust away, make sure to avoid inverting the can while spraying. This can cause frozen propellant to exit the can, which can cause serious problems with the glass and phosphor screen.

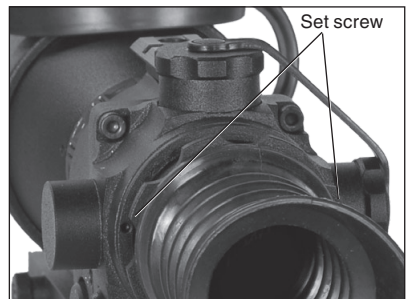

WARNINGS AND CAUTIONS

- Always remember to turn off the Aries scope when it is not in use. If you do not plan on using your aries scope for a period of more than 10 days, you should remove the batteries.
- **Keep lens cap/daylight filter on when not in use.**
- Avoid contact with dust, steam, and gas.
- The Aries scope is not harmful to the user or the environment.
- Do not disassemble except to clean the front lens and the eyepiece: **it will void your warranty.**
- Evaluate the scopes function by looking through it in a lit environment with the daylight filter lens cap on. Never use in daylight without the daylight filter lens cap on. Do not surpass ten minutes of testing.
- **Never point the Aries scope at a bright light source.** If the scope shuts off automatically after directing it at a bright light source, turn the unit off and wait 1 - 2 minutes before turning the unit back on.
- Adverse atmospheric conditions such as fog, smog, or haze and a lack of ambient light (moon or starlight) may diminish the effective viewing distance. All technical data for this unit was compiled in a controlled environment.
- If you use the rubber eyecaps for a long period of time, you may suffer skin inflammation. If you develop any symptoms, consult a doctor immediately.

TROUBLESHOOTING

Q: Flashes, flickers, or clicking occur while operating

S: If it occurs within the first five minutes of inserting new batteries, it is normal and the device will resume normal operation soon thereafter. If it occurs for more than 10 minutes, contact your dealer or other authorized service representative for service instructions.

Q: Dark spots on screen.

S: This may be dust on the lens, please clean according to instructions. They may also be Cosmetic blemishes in the intensifier tube which are a by-product of the manufacturing process. This is normal and will not affect the life or performance of the unit.

Q: Image not clear.

S: Adjust focus ring. If problem persists, increase viewing distance

Q: Fixed-pattern noise in a honeycomb shape.

S: Usually a cosmetic blemish characterized by a faint honeycomb-type pattern. This usually occurs when viewing very bright lights. Adjust the potentiometer, to reduce brightness.

Q: A pattern of dark thin lines which look like chicken wire.

S: Turn on illuminator, if purchased. If illuminator doesn't brighten image, replace batteries. If problem persists, contact ATN for service instructions.

2 YEAR PRODUCT WARRANTY

This product is guaranteed to be free from manufacturing defects in material and workmanship under normal use for a period of 2 (two) years from the date of purchase. In the event a defect that is covered by the foregoing warranty occurs during the applicable period stated above, ATN, at its option, will either repair or replace the product, and such action on the part of ATN shall be the full extent of ATN's liability, and the Customer's sole and exclusive remedy. This warranty does not cover a product (a) used in other than its normal and customary manner; (b) subjected to misuse; (c) subjected to alterations, modifications or repairs by the Customer of by any party other than ATN without prior written consent of ATN; (d) special order or "close-out" merchandise or merchandise sold "as-is" by either ATN or the ATN dealer; or (e) merchandise that has been discontinued by the manufacturer and either parts or replacement units are not available due to reasons beyond the control of ATN. ATN shall not be responsible for any defects or damage that in ATN's opinion is a result from the mishandling, abuse, misuse, improper storage or improper operation, including use in conjunction with equipment which is electrically or mechanically incompatible with or of inferior quality to the product, as well as failure to maintain the environmental conditions specified by the manufacturer. **CUSTOMER IS HEREBY NOTIFIED THAT OPERATION OF THE EQUIPMENT DURING DAYLIGHT HOURS OR UNDER ANY EXCESSIVE LIGHT CONDITIONS MAY PERMANENTLY DAMAGE THE INTERNAL COMPONENTS OF THE UNIT AND SAID DAMAGE WILL NOT BE COVERED UNDER THIS WARRANTY.** This warranty is extended only to the original purchaser. Any breach of this warranty shall be waived unless the customer notifies ATN at the address noted below within the applicable warranty period.

The customer understands and agrees that except for the foregoing warranty, no other warranties written or oral, statutory, expressed or implied, including any implied warranty of merchantability or fitness for a particular purpose, shall apply to the product. All such implied warranties are hereby and expressly disclaimed.

LIMITATION OF LIABILITY

ATN will not be liable for any claims, actions, suits, proceedings, costs, expenses, damages or liabilities arising out of the use of this product. Operation and use of the product are the sole responsibility of the Customer. ATN's sole undertaking is limited to providing the products and services outlined herein in accordance with the terms and conditions of this Agreement. The provision of products sold and services performed by ATN to the Customer shall not be interpreted, construed, or regarded, either expressly or implied, as being for the benefit of or creating any obligation toward any third party of legal entity outside ATN and the Customer; ATN's obligations under this Agreement extend solely to the Customer. **ATN's liability hereunder for damages, regardless of the form or action, shall not exceed the fees or other charges paid to ATN by the customer or customer's dealer. ATN shall not, in any event, be liable for special, indirect, incidental, or consequential damages, including, but not limited to, lost income, lost revenue, or lost profit, whether such damages were foreseeable or not at the time of purchase, and whether or not such damages arise out of a breach of warranty, a breach of agreement, negligence, strict liability or any other theory of liability.**

PRODUCT WARRANTY REGISTRATION

In order to validate the warranty on your product, ATN must receive a completed Product Warranty Registration Card for each unit or complete warranty registration on our website at www.atncorp.com. Please complete the included form and immediately mail it to our Service Center: ATN Corporation, 1341 San Mateo Avenue, South San Francisco, CA 94080.

OBTAINING WARRANTY SERVICE

To obtain warranty service on your unit, please contact our Customer Service department and request an RMA number. Once you have received your RMA # please mark this # on the outside of the shipping box and take or send the product, postage paid, with a copy of your sales receipt to our service center, ATN Corporation at the address noted above. All merchandise must be fully insured with the correct postage; ATN will not be responsible for improper postage or missing or damaged merchandise during shipment. Packages that do not have an RMA # clearly marked on the outside of the package will be delayed in being processed.



For customer service and technical support, please contact
American Technologies Network Corp.

North American Office

1341 San Mateo Avenue, South San Francisco, CA 94080
phone: 800-910-2862, 650-989-5100; fax: 650-875-0129

European Office

phone: 44(0)870-0111286, fax: 44(0) 845-3349142

The following countries can use our
toll free number 00 800 9102-8620

Austria, France, Germany, Holland, Italy, Spain, Sweden, Switzerland

www.atncorp.com