

# SR-PT Thermal Camera

## Installation and Operation Manual



**ThermalVideo.com**

**ThermalVideo.com**  
Your Source for Modern  
Thermal Imaging Systems  
P.O. BOX 4242  
Middletown, NY 10941

PH: + 1 888 919 2263  
PH Intl: + 1 845 343 4077  
FX: + 1 845 343 4299  
support@thermalvideo.com  
www.thermalvideo.com

### Camera Models

SR-100 PT	SR-50 PT
SR-35 PT	SR-19 PT

# ThermalVideo.com

**ThermalVideo.com**  
Your Source for Modern  
Thermal Imaging Systems

P.O. BOX 4242  
Middletown, NY 10941

PH: + 1 888 919 2263  
PH Intl: + 1 845 343 4077  
FX: + 1 845 343 4299  
support@thermalvideo.com  
www.thermalvideo.com

427-0027-01-10 Rev. 100

Date: May 29, 2009

Revision	Date	Notes
100	05/29/2009	Initial release

## EXPORT RESTRICTIONS

This document is controlled to FLIR Technology Level 2. The information contained in this document pertains to a dual use product controlled for export by the Export Administration Regulations (EAR). FLIR trade secrets contained herein are subject to disclosure restrictions as a matter of law. Diversion contrary to US law is prohibited. US Department of Commerce authorization is not required prior to export or transfer to foreign persons or parties unless otherwise prohibited.

## Table of Contents

WARNINGS AND CAUTIONS .....	4
Protect Your Investment .....	4
References .....	4
Introduction .....	5
SR-PT Camera Models .....	5
Camera .....	6
Description .....	6
SR-100 PT .....	6
SR-50 PT .....	6
SR-35 PT .....	6
SR-19 PT .....	6
Serial Remote Control .....	6
Installation .....	7
Ground Connection .....	7
Accessing the Electrical Connections .....	8
Power and Serial connections .....	10
Cable Leads .....	10
Input Power .....	10
SR-100 PT Connections .....	11
SR-19, SR-35, SR-50 Connections .....	12
Assembly of Camera to Pan/Tilt base .....	13
Mounting the SR-PT Camera .....	14
Camera Operation .....	17
IR Functions .....	17
Operational Temperatures .....	17
APPENDIX .....	18

## WARNINGS AND CAUTIONS

**Warning!** This guide uses the term **Warning!** to indicate a potentially hazardous situation, which, if not avoided, may result in bodily harm or injury, damage to the camera, or other property damage.

### Protect Your Investment

The camera should be installed by a trained professional according to local codes and industry-standard safe practices.

Proper ESD protocol should be followed while working inside the unit.

The camera is a precision optical instrument and should not be exposed to excessive shock or vibration.

Avoid pointing the system directly at extremely high-intensity radiation sources, such as the sun, lasers, arc welders, etc. This warning applies whether or not the system is powered.

Great care should be used with your camera's optics. They are delicate and can be damaged by improper cleaning. Only clean the lens in the manner described in SR-Series user manual.

### References

For additional information regarding installation of the SR camera, please refer to the [SR-Series Installation and Operation Manual](#) (Document number 427-0014-00-10).

If you have a question regarding installation or operation of your SR-PT camera, contact Thermal Video.com, Customer Support, using the contact information at the front of this manual. Check out our web site at (<http://www.thermalvideo.com>) to get information on courses offered and to learn how you can become a FLIR-authorized Installer.

Take care during installation to avoid scratching the camera lens. Do not expose the camera to direct sun for long periods without the sun shroud installed.

**Important!** All thermal imaging systems are subject to export control. Please contact FLIR for export compliance information concerning your application or geographic area.

## Introduction

The SR-PT Thermal Camera you have purchased is a sophisticated thermal imaging camera that provides excellent night visibility and situational awareness, even in absolute darkness. The camera has a standard video output that works with digital video recording devices, video motion detection software or off-the-shelf video encoders.

FLIR's powerful SR-PT thermal security cameras compliment and complete your security camera network. They turn night into day, allowing you to see intruders invisible to the naked eye. SR-PT cameras create video images from infrared thermal energy (heat), and perform well at night and day, in good weather and bad. The SR Series thermal surveillance camera system is intended for various commercial and industrial applications, including security and surveillance.



**Figure 0-1 : Daylight camera on left; Thermal image on right**

Observe that the image on the left from an ordinary daylight camera is obscured by fog; the thermal image on the right provides clear details.

The SR-PT camera is designed for simple, intuitive installation and operation. Each camera is based on FLIR's widely-deployed uncooled microbolometer imaging core. All cameras include FLIR's advanced image processing techniques which deliver excellent contrast regardless of scene dynamics. Unlike other night vision systems that require low amounts of light to generate an image, the SR-PT thermal imagers need no light at all.

### **SR-PT Camera Models**

The cameras are available with a choice of lenses for short-, medium- and long-range surveillance capability.

Camera	Description
<b>SR-100 PT</b>	The 7° horizontal field of view of the SR-100 provides long range surveillance with high visual acuity of distant targets. The camera features a motorized lens for adjustable focus. Like all SR-PT cameras, the SR-100 provides crisp, clear thermal imagery in total darkness, light fog or smoke.
<b>SR-50 PT</b>	Utilizing a 50mm lens, the SR-50 serves as a medium-range surveillance camera and provides a 14° HFOV. This focal length is widely deployed because it provides an even balance between situational awareness and detailed perspective.
<b>SR-35 PT</b>	The SR-35 camera features a focal length of 35mm, providing a short to medium field of view of 20° and is well-suited for short range threat detection in all circumstances.
<b>SR-19 PT</b>	The SR-19 camera features a focal length of 19mm (36° HFOV) and, like the other SR-PT cameras, has a standard resolution Focal Plane Array (FPA) with 320x240 pixels (320x256 PAL format). It gives you an extremely wide field of view, so that you can cover a large area and keep excellent situational awareness.

## ***Serial Remote Control***

The SR-PT cameras support serial communication for control of camera pan/tilt, focus (SR-100 PT only) and other features. Each camera is pre-configured at the factory to support RS-422 protocol. Users can control the camera with devices that support the Pelco® D protocol. Such devices allow the user to operate the following functions or features:

- Camera pan (360° continuous pan)
- Camera tilt (from +33° to -83° azimuth)
- Camera focus (SR-100 only)
- Digital zoom (2X)
- Camera Palette (also known as Polarity) - by default the White Hot palette is used; alternatively the Black Hot palette displays warmer objects as black or dark rather than white or light shades. Additional pseudo color palettes are available using the application software supplied with the camera.

## Installation

The SR-PT Thermal Imaging camera is packaged in a separate box from the pan/tilt base. The wires from the base will need to be connected to the camera through an opening in the back of the camera and the camera will need to be installed on the top of the pan/tilt base. Then the connections to the assembled unit are made.

### Ground Connection

The SR-PT cameras have grounding and surge protection to provide further immunity from high current transients that can occur in installations that are subject to electrical storms and/or nearby lightning events. **In order to ensure CE and FCC compliance as well as to protect against these high current events**, installers are required to provide an Earth connection to a specific connection on the camera assembly. Note: a ground connection to the exterior of the camera (for example, to the mounting foot) is insufficient.

When the camera is shipped from FLIR, an internal ground wire (green) connects the interface board to the Earth Ground Lug, located on the inside of the rear of the enclosure. If it is disconnected during the installation, it must be reconnected. For proper installation, a ground connection from an external Earth ground must be connected to the Earth Ground wire on the pan/tilt base, and from the pan/tilt base to the Earth Ground Lug inside the rear cover of the camera. Typically the Earth ground connection will be part of the power cable bundle.

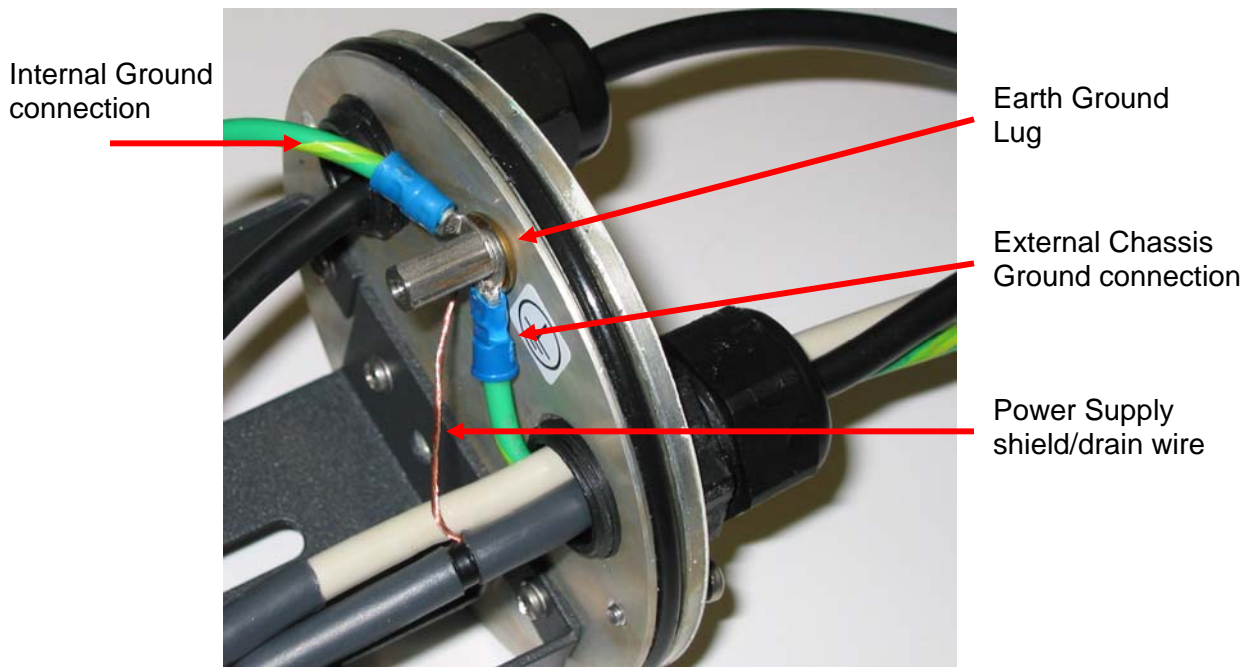

**Figure 1: Earth Ground Connection**

**Warning!** The camera must be installed according to industry-standard practices and local electrical codes. Failure to properly connect the enclosure and the electrical interface board to ground could result in damage to the camera and possible bodily injury.

## Accessing the Electrical Connections

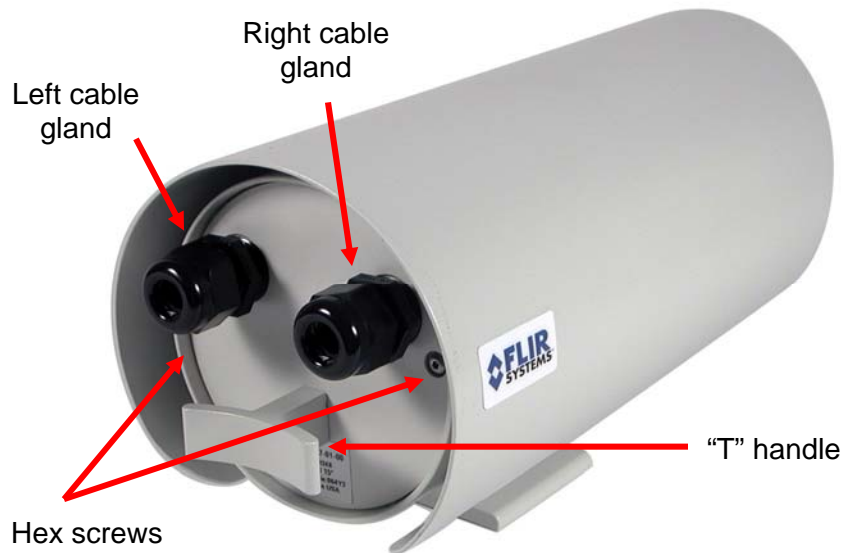

**Figure 2: SR-Series Camera**

The rear of the enclosure must be removed in order to access the electrical connections. Locate the plastic bag that includes some of the small items that will be required for the installation (includes hex keys, set screws, cotter pin, gland plug, and so on).

It is necessary to connect the camera to the cable attached to the pan/tilt base prior to physically mounting the camera to the pan/tilt base. Remove the rear cover of the camera using a 5/64" hex wrench. Temporarily disconnect the green and yellow ground cable from the camera to the inside of the rear cover. With the rear cover off, the screw-terminal connector inside the camera is accessible. This connector can be detached from the unit by gently pulling on it. When replacing it, be careful to maintain the proper orientation when connecting the leads and reinserting the connector to the camera.

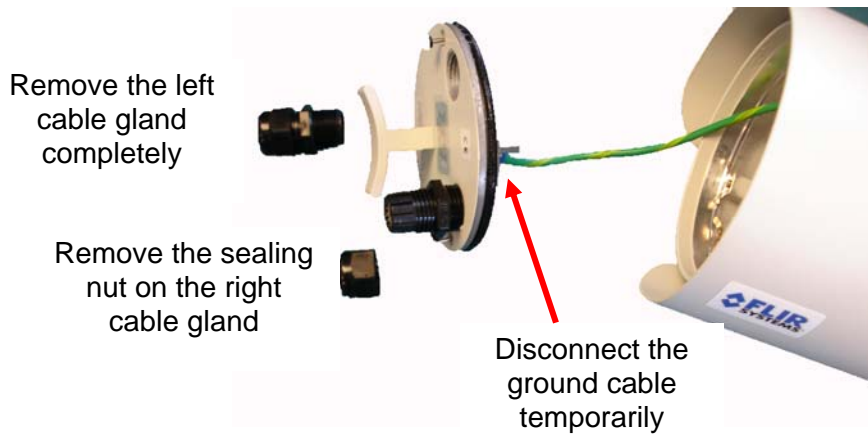

Completely remove the left cable gland assembly (it will be replaced by the cable gland that is attached to the cable from the base). Apply Teflon tape to the threads of the cable gland that is on the cable. Attach the camera rear cover to the cable by inserting the leads through the left hole (start with the BNC-terminated video cable) and then thread the cover onto the cable gland. Rotate the cover to tighten it onto the gland and then rotate the gland on the cable so that the t-handle is down (below the cable) when the cable is bent over the base, as it will be when the camera is mounted. Then tighten the sealing nut.

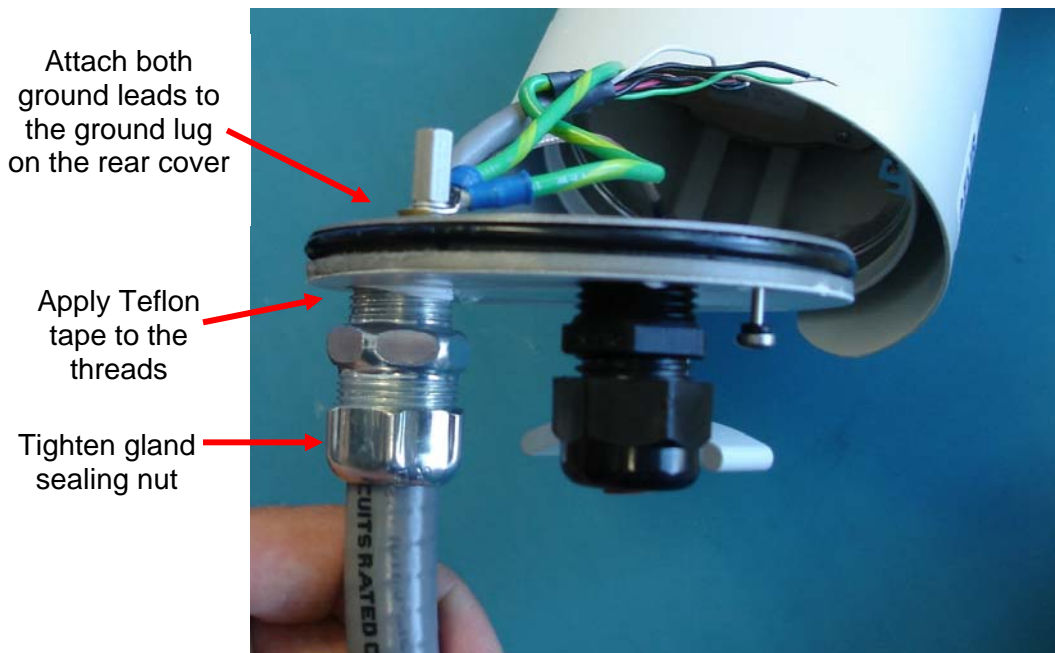

**Figure 3: Rear Cover connected to cable**

An orange plug is used to seal the right cable gland. Temporarily remove the sealing nut on the right cable gland, insert the orange plug into the gland, and replace the sealing nut. When the sealing nut is tightened, the plug should be flush with the back of the sealing nut.



**Figure 4: Cable Gland Plug Installed**

### **Power and Serial connections**

The SR-PT camera provides electrical contacts in the form of screw-terminal jacks, allowing it to receive 16-24 AWG tinned leads from the power supply and serial communication interface. The SR-100 camera has a green terminal block, and the terminal block for the other SR-Series cameras is black; however the terminal designations are the same for all cameras.

Note: The serial communications protocol to the SR-PT camera base uses the RS-422 protocol. However, between the pan/tilt base and the camera, the RS-232 protocol is used.

### **Cable Leads**



- White: AC Power - A
- Black (single wire): AC Power - B
- Black (2 wires): RS-232 ground
- Red: RS-232 Data Receive
- Green: RS-232 Data Transmit
- Green/yellow: Earth Ground
- Tan with BNC: Video

### **Input Power**

The SR-PT cameras operate 24VAC power (nominal). The cameras provide screw-terminals for receiving tinned leads for input power. The power cable should be twisted pair or triple, with an

overall shield or conduit connected to the enclosure rear panel ground lug, as described in the previous section.

The camera is fuse-protected against over-voltage conditions. A blown fuse is an indication either that the circuit has been overloaded or that a short circuit has occurred somewhere in the circuit. A wiring problem may be placing too much of a load on the circuit if a fuse blows after plugging in or turning on the camera. Before replacing the fuse it is important to identify what has caused it to fail.

Prior to changing a fuse, turn off the electrical circuit or completely disconnect the camera. Make certain that no dangerous condition exists before restoring power. Replace the fuse with a fuse that is of the same rating and proper for the circuit. Never use anything other than a fuse of

**Warning!** Failure to disconnect power to the camera while replacing a fuse could result in accidental injury or death.

## SR-100 PT Connections

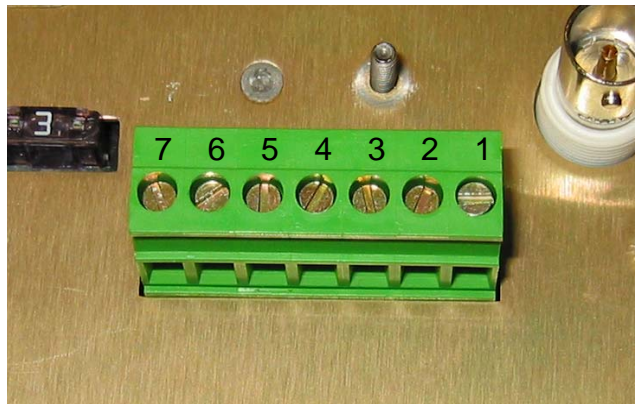

**Figure 5: SR-100 Screw Terminal Connector**

Pin number	Description	Wire color	Comments
1	RS232 Tx	Green	RS-232: Transmit Data (TD)
2	Not used	Not used	Not used
3	RS232 Rx	Red	RS-232: Receive Data (RD)
4	Not used	Not used	Not used
5	Ground	Black (2 wires)	GND
6	-Voltage In	Black (single wire)	AC B
7	+Voltage In	White	AC A

**Table 1: SR-100 Screw Terminals**

**SR-19, SR-35, SR-50 Connections**

The SR-19, SR-35, and SR-50 camera systems each have a fixed-focus lens (focused at hyperfocal distance at the factory) and the lens focus is not field adjustable.



Note: the pin numbers are not designated on the connector.

Connector Pin	Used for Power or Serial Communications	Wire color	Comments
1	Serial	Green	RS-232: Transmit Data (TD)
2	Serial		Not used
3	Serial	Red	RS-232: Receive Data (RD)
4	Serial		Not used
5	Serial	Black (2 wires)	Signal Ground
6	Power	Black (single wire)	AC A
7	Power	White	AC A
		Note:	Be sure to connect the ground to the lug inside the rear cover

**Table 2: Power and Serial Pin Designations**

### ***Assembly of Camera to Pan/Tilt base***

The SR-PT camera attaches to the pan/tilt base by inserting the foot of the camera into the shoe at the top of the base. The camera is secured to the base with 4 set screws, two on each side of the shoe. A cotter pin is inserted through the shoe in front of the foot of the camera for additional security.

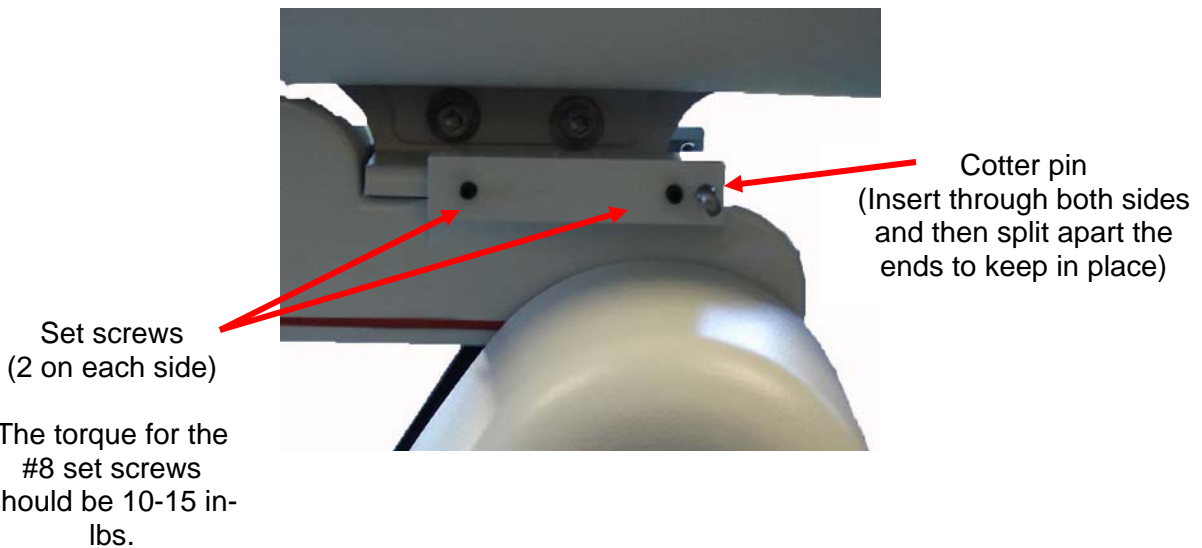
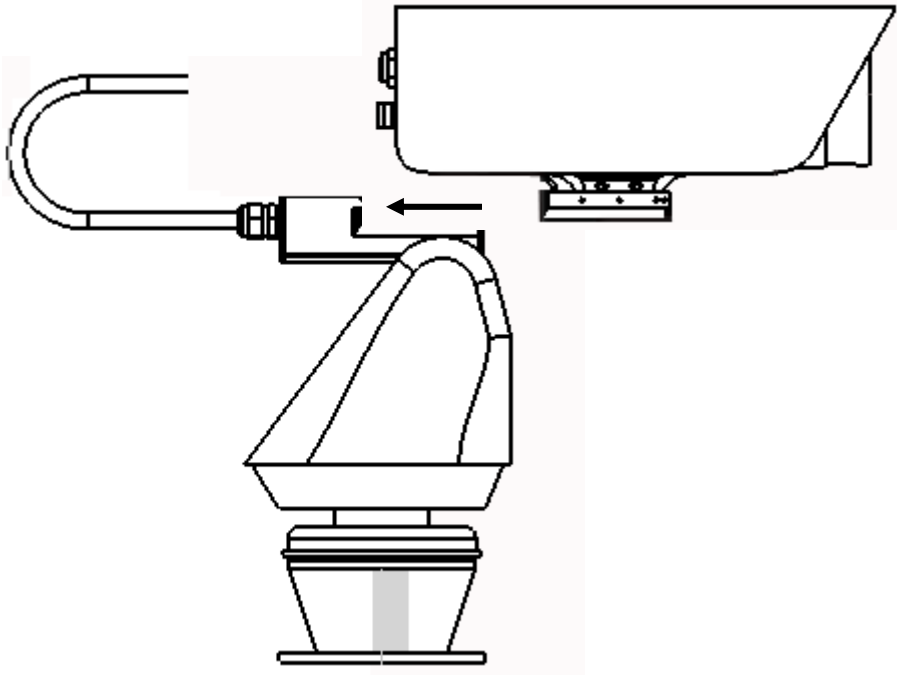

## Mounting the SR-PT Camera

When installing the SR-PT system, allow for sufficient clearance between the top of the unit and overhead obstructions. This will prevent interference when the enclosure is driven to its maximum elevation.

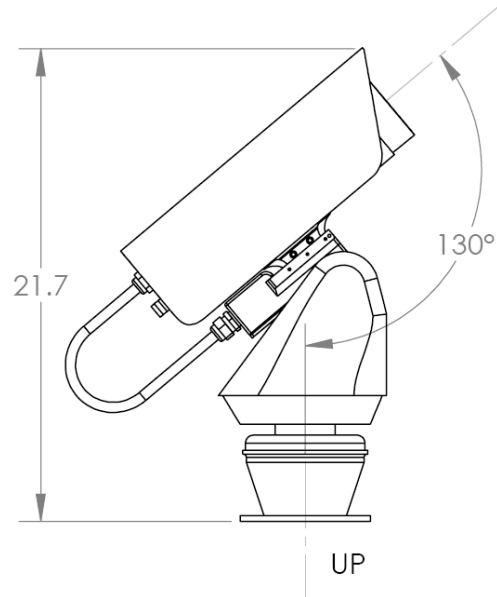

Remove the transformer module from the base of the system by loosening the four Phillips screws and lifting the module.

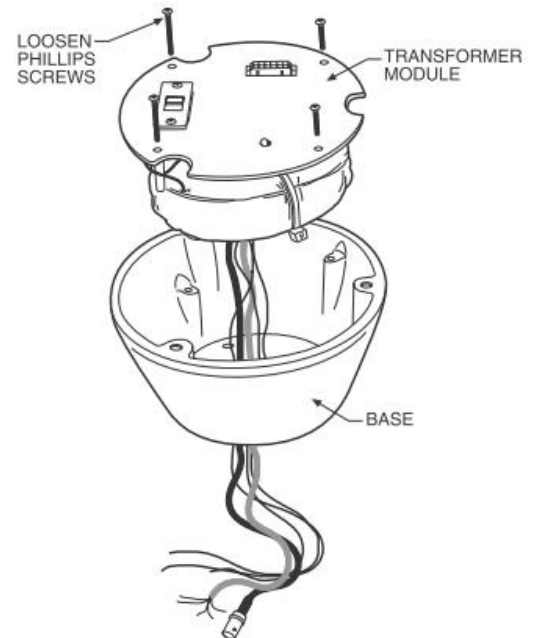

Attach the base of the system to the included base plate with the three flathead 10-32 x 1/2-inch screws and washers (supplied).

Route the wires and cables through the center of the base plate mount. Reinstall the transformer module into the base. The transformer module can be positioned in the mount base in only one orientation.

Connect wires and cables.

- A. Connect to power. Use the two supplied clamp connectors to connect the AC line and neutral.

24 VAC	
White Wire	Input (AC Line)
White Wire	AC Neutral
Green Wire	Ground

- B. Connect the video coaxial cable to the BNC connector.
- C. Connect the wiring for a two-wire or four-wire control system.

Green Wire	RX-
Red Wire	RX+
Black Wire	TX-
White Wire	TX+

Install the mount and base assembly in its intended location. Refer to the installation manual supplied with the mount for instructions.

Turn on the power. If the red LED lights, turn off the power and proceed to the next step. If the red LED does not light, refer to the Troubleshooting section.

Plug the male system connector, located on the bottom of the pan and tilt, into the female system connector located on the transformer module. Align the pan and tilt part number with the alignment label of the base and then attach the pan and tilt to the base with three 1/4-20 nuts and washers (supplied).

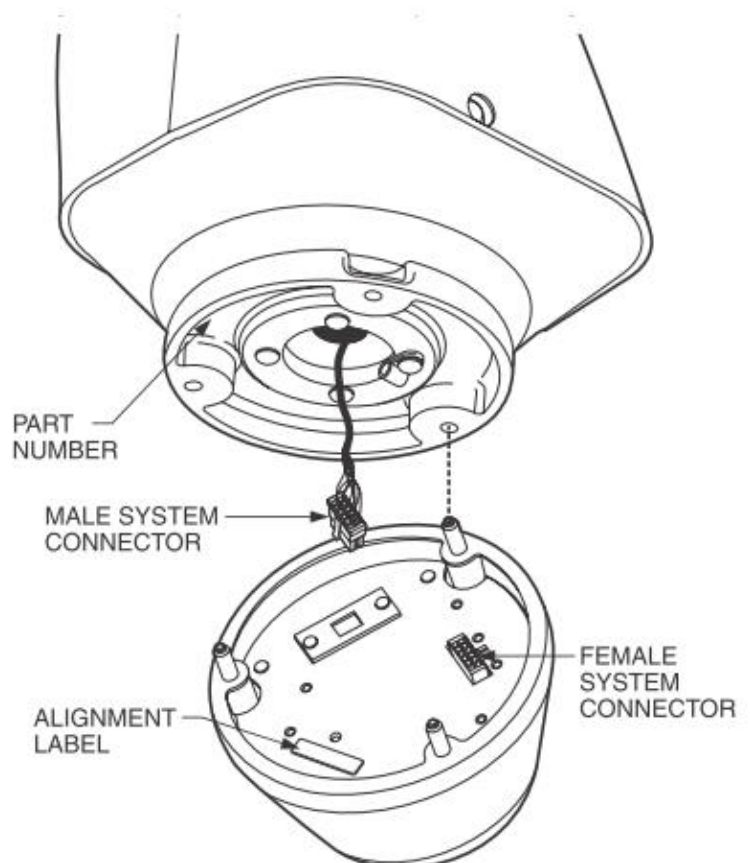

Set the receiver address and system baud rate by configuring DIP switches SW1 and SW2. The factory default baud rate is 2400. To set the DIP switches:

- A. Remove the plug from the left cover of the pan and tilt. It is not necessary to remove the pan and tilt cover.
- B. Set the baud rate (SW1) and receiver address (SW2). For switch settings refer to tables A and B in the Appendix.
- C. Replace the plug.

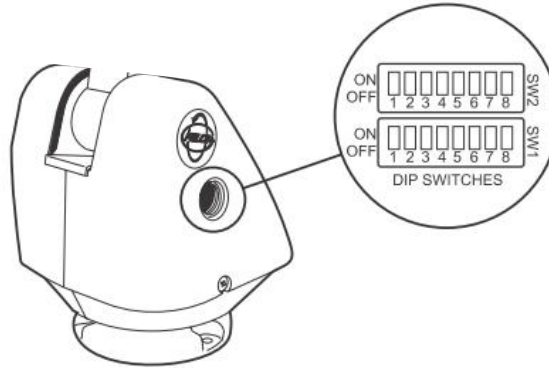

**NOTE:** Switch settings have no effect on Coaxitron control signals. The SR-PT will sense and automatically select input from Coaxitron control signals in either standard or extended mode.

For more information please refer to the Pelco ES3012 Series Esprit Manual

## Camera Operation

The camera supports a subset of the Pelco D functions. If you have a question regarding installation or operation of your SR-PT camera, contact FLIR Systems, Inc Customer Support, using the contact information at the front of this manual.

## IR Functions

There are three IR functions that can be manipulated via a typical Pelco Joystick controller. They are as follows:

### Digital Zoom:

Twist right = 2x zoom

Twist left = 1x zoom

### Black Hot/White Hot:

Iris open = Black hot

Iris close = White hot

### Focus (SR-100 PT only):

Near = Focus Near

Far = Focus Far



## Operational Temperatures

Please note that the operating temperatures for the SR-PT Thermal Camera are -32<sup>0</sup> to 50<sup>0</sup> C.

## APPENDIX

**NOTE:** *Esprit will sense and automatically select input from Coaxitron control signals in either the standard or extended mode. Therefore, the DIP switches settings have no effect on Coaxitron control signals.*

**Table A.** Switch Settings for SW1

Baud Rate	Switch Setting		
	SW1-1	SW1-2	SW1-3
2400	OFF	OFF	OFF*
4800	ON	OFF	OFF*
9600	OFF	ON	OFF*

\* SW1-3 is not used; set it in the OFF position.

		Switch Setting			
SW1-4	SW1-5	SW1-6	SW1-7	SW1-8	
OFF*	Note (1)	Note (2)	Note (3)	Note (4)	
<b>NOTES:</b>					
(1)	SW1-5	OFF - For controllers that have more than 32 presets. ON - For American Dynamics controllers (32 presets).			
(2)	SW1-6	OFF - For all control systems except CM9502 with <b>variable</b> speed keyboards. For CM9502 with <b>fixed</b> speed keyboards, set switch OFF. ON - For CM9502 with <b>variable</b> speed keyboards to get smoother joystick control.			
(3)	SW1-7	OFF - RS-422 transmitter is not terminated. ON - RS-422 transmitter is terminated.			
(4)	SW1-8	OFF - RS-422 receiver is not terminated. ON - RS-422 receiver is terminated.			

\* SW1-4 is not used; set it in the OFF position.

**Table B.** Switch Settings for SW2

**NOTE:** The Esprit will sense and automatically select input from Coaxitron control signals in either the standard or extended mode. Therefore, the DIP switches settings have no effect on Coaxitron control signals.

Receiver Address		Switch Setting							
P-Type	D-Type	SW2-1	SW2-2	SW2-3	SW2-4	SW2-5	SW2-6	SW2-7	SW2-8
Control	Control								
1	-	OFF	OFF	OFF	OFF	OFF	OFF	OFF	OFF
2	1	ON	OFF	OFF	OFF	OFF	OFF	OFF	OFF
3	2	OFF	ON	OFF	OFF	OFF	OFF	OFF	OFF
4	3	ON	ON	OFF	OFF	OFF	OFF	OFF	OFF
5	4	OFF	OFF	ON	OFF	OFF	OFF	OFF	OFF
6	5	ON	OFF	ON	OFF	OFF	OFF	OFF	OFF
7	6	OFF	ON	ON	OFF	OFF	OFF	OFF	OFF
8	7	ON	ON	ON	OFF	OFF	OFF	OFF	OFF
9	8	OFF	OFF	OFF	ON	OFF	OFF	OFF	OFF
10	9	ON	OFF	OFF	ON	OFF	OFF	OFF	OFF
11	10	OFF	ON	OFF	ON	OFF	OFF	OFF	OFF
12	11	ON	ON	OFF	ON	OFF	OFF	OFF	OFF
13	12	OFF	OFF	ON	ON	OFF	OFF	OFF	OFF
14	13	ON	OFF	ON	ON	OFF	OFF	OFF	OFF
15	14	OFF	ON	ON	ON	OFF	OFF	OFF	OFF
16	15	ON	ON	ON	ON	OFF	OFF	OFF	OFF
17	16	OFF	OFF	OFF	OFF	ON	OFF	OFF	OFF
18	17	ON	OFF	OFF	OFF	ON	OFF	OFF	OFF
19	18	OFF	ON	OFF	OFF	ON	OFF	OFF	OFF
20	19	ON	ON	OFF	OFF	ON	OFF	OFF	OFF
21	20	OFF	OFF	ON	OFF	ON	OFF	OFF	OFF
22	21	ON	OFF	ON	OFF	ON	OFF	OFF	OFF
23	22	OFF	ON	ON	OFF	ON	OFF	OFF	OFF
24	23	ON	ON	ON	OFF	ON	OFF	OFF	OFF
25	24	OFF	OFF	OFF	ON	ON	OFF	OFF	OFF
26	25	ON	OFF	OFF	ON	ON	OFF	OFF	OFF
27	26	OFF	ON	OFF	ON	ON	OFF	OFF	OFF
28	27	ON	ON	OFF	ON	ON	OFF	OFF	OFF
29	28	OFF	OFF	ON	ON	ON	OFF	OFF	OFF
30	29	ON	OFF	ON	ON	ON	OFF	OFF	OFF
31	30	OFF	ON	ON	ON	ON	OFF	OFF	OFF
32	31	ON	ON	ON	ON	ON	OFF	OFF	OFF
-	32	OFF	OFF	OFF	OFF	OFF	ON	OFF	OFF
-	33	ON	OFF	OFF	OFF	OFF	ON	OFF	OFF
-	34	OFF	ON	OFF	OFF	OFF	ON	OFF	OFF
-	35	ON	ON	OFF	OFF	OFF	ON	OFF	OFF
-	36	OFF	OFF	ON	OFF	OFF	ON	OFF	OFF
-	37	ON	OFF	ON	OFF	OFF	ON	OFF	OFF
-	38	OFF	ON	ON	OFF	OFF	ON	OFF	OFF
-	39	ON	ON	ON	OFF	OFF	ON	OFF	OFF
-	40	OFF	OFF	OFF	ON	OFF	ON	OFF	OFF
-	41	ON	OFF	OFF	ON	OFF	ON	OFF	OFF
-	42	OFF	ON	OFF	ON	OFF	ON	OFF	OFF
-	43	ON	ON	OFF	ON	OFF	ON	OFF	OFF
-	44	OFF	OFF	ON	ON	OFF	ON	OFF	OFF
-	45	ON	OFF	ON	ON	OFF	ON	OFF	OFF
-	46	OFF	ON	ON	ON	OFF	ON	OFF	OFF
-	47	ON	ON	ON	ON	OFF	ON	OFF	OFF
-	48	OFF	OFF	OFF	OFF	ON	ON	OFF	OFF
-	49	ON	OFF	OFF	OFF	ON	ON	OFF	OFF
-	50	OFF	ON	OFF	OFF	ON	ON	OFF	OFF
-	51	ON	ON	OFF	OFF	ON	ON	OFF	OFF
-	52	OFF	OFF	ON	OFF	ON	ON	OFF	OFF
-	53	ON	OFF	ON	OFF	ON	ON	OFF	OFF
-	54	OFF	ON	ON	OFF	ON	ON	OFF	OFF
-	55	ON	ON	ON	OFF	ON	ON	OFF	OFF

Receiver Address		Switch Setting							
P-Type	D-Type	SW2-1	SW2-2	SW2-3	SW2-4	SW2-5	SW2-6	SW2-7	SW2-8
Control	Control								
-	56	OFF	OFF	OFF	ON	ON	ON	OFF	OFF
-	57	ON	OFF	OFF	ON	ON	ON	OFF	OFF
-	58	OFF	ON	OFF	ON	ON	ON	OFF	OFF
-	59	ON	ON	OFF	ON	ON	ON	OFF	OFF
-	60	OFF	OFF	ON	ON	ON	ON	OFF	OFF
-	61	ON	OFF	ON	ON	ON	ON	OFF	OFF
-	62	OFF	ON	ON	ON	ON	ON	OFF	OFF
-	63	ON	ON	ON	ON	ON	ON	OFF	OFF
-	64	OFF	OFF	OFF	OFF	OFF	OFF	ON	OFF
-	65	ON	OFF	OFF	OFF	OFF	OFF	ON	OFF
-	66	OFF	ON	OFF	OFF	OFF	OFF	ON	OFF
-	67	ON	ON	OFF	OFF	OFF	OFF	ON	OFF
-	68	OFF	OFF	ON	OFF	OFF	OFF	ON	OFF
-	69	ON	OFF	ON	OFF	OFF	OFF	ON	OFF
-	70	OFF	ON	ON	OFF	OFF	OFF	ON	OFF
-	71	ON	ON	ON	OFF	OFF	OFF	ON	OFF
-	72	OFF	OFF	OFF	ON	OFF	OFF	ON	OFF
-	73	ON	OFF	OFF	ON	OFF	OFF	ON	OFF
-	74	OFF	ON	OFF	ON	OFF	OFF	ON	OFF
-	75	ON	ON	OFF	ON	OFF	OFF	ON	OFF
-	76	OFF	OFF	ON	ON	OFF	OFF	ON	OFF
-	77	ON	OFF	ON	ON	OFF	OFF	ON	OFF
-	78	OFF	ON	ON	ON	OFF	OFF	ON	OFF
-	79	ON	ON	ON	ON	OFF	OFF	ON	OFF
-	80	OFF	OFF	OFF	OFF	ON	OFF	ON	OFF
-	81	ON	OFF	OFF	OFF	ON	OFF	ON	OFF
-	82	OFF	ON	OFF	OFF	ON	OFF	ON	OFF
-	83	ON	ON	OFF	OFF	ON	OFF	ON	OFF
-	84	OFF	OFF	ON	OFF	ON	OFF	ON	OFF
-	85	ON	OFF	ON	OFF	ON	OFF	ON	OFF
-	86	OFF	ON	ON	OFF	ON	OFF	ON	OFF
-	87	ON	ON	ON	OFF	ON	OFF	ON	OFF
-	88	OFF	OFF	OFF	ON	ON	OFF	ON	OFF
-	89	ON	OFF	OFF	ON	ON	OFF	ON	OFF
-	90	OFF	ON	OFF	ON	ON	OFF	ON	OFF
-	91	ON	ON	OFF	ON	ON	OFF	ON	OFF
-	92	OFF	OFF	ON	ON	ON	OFF	ON	OFF
-	93	ON	OFF	ON	ON	ON	OFF	ON	OFF
-	94	OFF	ON	ON	ON	ON	OFF	ON	OFF
-	95	ON	ON	ON	ON	ON	OFF	ON	OFF
-	96	OFF	OFF	OFF	OFF	OFF	ON	ON	OFF
-	97	ON	OFF	OFF	OFF	OFF	ON	ON	OFF
-	98	OFF	ON	OFF	OFF	OFF	ON	ON	OFF
-	99	ON	ON	OFF	OFF	OFF	ON	ON	OFF
-	100	OFF	OFF	ON	OFF	OFF	ON	ON	OFF
-	101	ON	OFF	ON	OFF	OFF	ON	ON	OFF
-	102	OFF	ON	ON	OFF	OFF	ON	ON	OFF
-	103	ON	ON	ON	OFF	OFF	ON	ON	OFF
-	104	OFF	OFF	OFF	ON	OFF	ON	ON	OFF
-	105	ON	OFF	OFF	ON	OFF	ON	ON	OFF
-	106	OFF	ON	OFF	ON	OFF	ON	ON	OFF
-	107	ON	ON	OFF	ON	OFF	ON	ON	OFF
-	108	OFF	OFF	ON	ON	OFF	ON	ON	OFF
-	109	ON	OFF	ON	ON	OFF	ON	ON	OFF
-	110	OFF	ON	ON	ON	OFF	ON	ON	OFF
-	111	ON	ON	ON	ON	OFF	ON	ON	OFF

(Continued on next page)

**Table B. Switch Settings for SW2 (continued)**

Receiver Address		Switch Setting							
P-Type Control	D-Type Control	SW2-1	SW2-2	SW2-3	SW2-4	SW2-5	SW2-6	SW2-7	SW2-8
-	112	OFF	OFF	OFF	OFF	ON	ON	ON	OFF
-	113	ON	OFF	OFF	OFF	ON	ON	ON	OFF
-	114	OFF	ON	OFF	OFF	ON	ON	ON	OFF
-	115	ON	ON	OFF	OFF	ON	ON	ON	OFF
-	116	OFF	OFF	ON	OFF	ON	ON	ON	OFF
-	117	ON	OFF	ON	OFF	ON	ON	ON	OFF
-	118	OFF	ON	ON	OFF	ON	ON	ON	OFF
-	119	ON	ON	ON	OFF	ON	ON	ON	OFF
-	120	OFF	OFF	OFF	ON	ON	ON	ON	OFF
-	121	ON	OFF	OFF	ON	ON	ON	ON	OFF
-	122	OFF	ON	OFF	ON	ON	ON	ON	OFF
-	123	ON	ON	OFF	ON	ON	ON	ON	OFF
-	124	OFF	OFF	ON	ON	ON	ON	ON	OFF
-	125	ON	OFF	ON	ON	ON	ON	ON	OFF
-	126	OFF	ON	ON	ON	ON	ON	ON	OFF
-	127	ON	ON	ON	ON	ON	ON	ON	OFF
-	128	OFF	OFF	OFF	OFF	OFF	OFF	OFF	ON
-	129	ON	OFF	OFF	OFF	OFF	OFF	OFF	ON
-	130	OFF	ON	OFF	OFF	OFF	OFF	OFF	ON
-	131	ON	ON	OFF	OFF	OFF	OFF	OFF	ON
-	132	OFF	OFF	ON	OFF	OFF	OFF	OFF	ON
-	133	ON	OFF	ON	OFF	OFF	OFF	OFF	ON
-	134	OFF	ON	ON	OFF	OFF	OFF	OFF	ON
-	135	ON	ON	ON	OFF	OFF	OFF	OFF	ON
-	136	OFF	OFF	OFF	ON	OFF	OFF	OFF	ON
-	137	ON	OFF	OFF	ON	OFF	OFF	OFF	ON
-	138	OFF	ON	OFF	ON	OFF	OFF	OFF	ON
-	139	ON	ON	OFF	ON	OFF	OFF	OFF	ON
-	140	OFF	OFF	ON	ON	OFF	OFF	OFF	ON
-	141	ON	OFF	ON	ON	OFF	OFF	OFF	ON
-	142	OFF	ON	ON	ON	OFF	OFF	OFF	ON
-	143	ON	ON	ON	ON	OFF	OFF	OFF	ON
-	144	OFF	OFF	OFF	OFF	ON	OFF	OFF	ON
-	145	ON	OFF	OFF	OFF	ON	OFF	OFF	ON
-	146	OFF	ON	OFF	OFF	ON	OFF	OFF	ON
-	147	ON	ON	OFF	OFF	ON	OFF	OFF	ON
-	148	OFF	OFF	ON	OFF	ON	OFF	OFF	ON
-	149	ON	OFF	ON	OFF	ON	OFF	OFF	ON
-	150	OFF	ON	ON	OFF	ON	OFF	OFF	ON
-	151	ON	ON	ON	OFF	ON	OFF	OFF	ON
-	152	OFF	OFF	OFF	ON	ON	OFF	OFF	ON
-	153	ON	OFF	OFF	ON	ON	OFF	OFF	ON
-	154	OFF	ON	OFF	ON	ON	OFF	OFF	ON
-	155	ON	ON	OFF	ON	ON	OFF	OFF	ON
-	156	OFF	OFF	ON	ON	ON	OFF	OFF	ON
-	157	ON	OFF	ON	ON	ON	OFF	OFF	ON
-	158	OFF	ON	ON	ON	ON	OFF	OFF	ON
-	159	ON	ON	ON	ON	ON	OFF	OFF	ON
-	160	OFF	OFF	OFF	OFF	ON	OFF	OFF	ON
-	161	ON	OFF	OFF	OFF	ON	OFF	OFF	ON
-	162	OFF	ON	OFF	OFF	ON	ON	OFF	ON
-	163	ON	ON	OFF	OFF	ON	ON	OFF	ON
-	164	OFF	OFF	ON	OFF	ON	ON	OFF	ON
-	165	ON	OFF	ON	OFF	ON	ON	OFF	ON
-	166	OFF	ON	ON	OFF	ON	ON	OFF	ON
-	167	ON	ON	ON	OFF	ON	ON	OFF	ON
-	168	OFF	OFF	OFF	ON	OFF	ON	OFF	ON
-	169	ON	OFF	OFF	ON	OFF	ON	OFF	ON
-	170	OFF	ON	OFF	ON	OFF	ON	OFF	ON
-	171	ON	ON	OFF	ON	OFF	ON	OFF	ON

Receiver Address		Switch Setting							
P-Type Control	D-Type Control	SW2-1	SW2-2	SW2-3	SW2-4	SW2-5	SW2-6	SW2-7	SW2-8
-	172	OFF	OFF	ON	ON	OFF	ON	OFF	ON
-	173	ON	OFF	ON	ON	OFF	ON	OFF	ON
-	174	OFF	ON	ON	ON	OFF	ON	OFF	ON
-	175	ON	ON	ON	ON	OFF	ON	OFF	ON
-	176	OFF	OFF	OFF	OFF	ON	ON	OFF	ON
-	177	ON	OFF	OFF	OFF	ON	ON	OFF	ON
-	178	OFF	ON	OFF	OFF	ON	ON	OFF	ON
-	179	ON	ON	OFF	OFF	ON	ON	OFF	ON
-	180	OFF	OFF	ON	OFF	ON	ON	OFF	ON
-	181	ON	OFF	ON	OFF	ON	ON	OFF	ON
-	182	OFF	ON	ON	OFF	ON	ON	OFF	ON
-	183	ON	ON	ON	OFF	ON	ON	OFF	ON
-	184	OFF	OFF	OFF	ON	ON	ON	OFF	ON
-	185	ON	OFF	OFF	ON	ON	ON	OFF	ON
-	186	OFF	ON	OFF	ON	ON	ON	OFF	ON
-	187	ON	ON	OFF	ON	ON	ON	OFF	ON
-	188	OFF	OFF	ON	ON	ON	ON	OFF	ON
-	189	ON	OFF	ON	ON	ON	ON	OFF	ON
-	190	OFF	ON	ON	ON	ON	ON	OFF	ON
-	191	ON	ON	ON	ON	ON	ON	OFF	ON
-	192	OFF	OFF	OFF	OFF	OFF	OFF	ON	ON
-	193	ON	OFF	OFF	OFF	OFF	OFF	ON	ON
-	194	OFF	ON	OFF	OFF	OFF	OFF	ON	ON
-	195	ON	ON	OFF	OFF	OFF	OFF	ON	ON
-	196	OFF	OFF	ON	OFF	OFF	OFF	ON	ON
-	197	ON	OFF	ON	OFF	OFF	OFF	ON	ON
-	198	OFF	ON	ON	OFF	OFF	OFF	ON	ON
-	199	ON	ON	ON	OFF	OFF	OFF	ON	ON
-	200	OFF	OFF	OFF	ON	OFF	OFF	ON	ON
-	201	ON	OFF	OFF	ON	OFF	OFF	ON	ON
-	202	OFF	ON	OFF	ON	OFF	OFF	ON	ON
-	203	ON	ON	OFF	ON	OFF	OFF	ON	ON
-	204	OFF	OFF	ON	ON	OFF	OFF	ON	ON
-	205	ON	OFF	ON	ON	OFF	OFF	ON	ON
-	206	OFF	ON	ON	ON	OFF	OFF	ON	ON
-	207	ON	ON	ON	ON	OFF	OFF	ON	ON
-	208	OFF	OFF	OFF	OFF	ON	OFF	ON	ON
-	209	ON	OFF	OFF	OFF	ON	OFF	ON	ON
-	210	OFF	ON	OFF	OFF	ON	OFF	ON	ON
-	211	ON	ON	OFF	OFF	ON	OFF	ON	ON
-	212	OFF	OFF	ON	OFF	ON	OFF	ON	ON
-	213	ON	OFF	ON	OFF	ON	OFF	ON	ON
-	214	OFF	ON	ON	OFF	ON	OFF	ON	ON
-	215	ON	ON	ON	OFF	ON	OFF	ON	ON
-	216	OFF	OFF	OFF	ON	ON	OFF	ON	ON
-	217	ON	OFF	OFF	ON	ON	OFF	ON	ON
-	218	OFF	ON	OFF	ON	ON	OFF	ON	ON
-	219	ON	ON	OFF	ON	ON	OFF	ON	ON
-	220	OFF	OFF	ON	ON	ON	OFF	ON	ON
-	221	ON	OFF	ON	ON	ON	OFF	ON	ON
-	222	OFF	ON	ON	ON	ON	OFF	ON	ON
-	223	ON	ON	ON	ON	ON	OFF	ON	ON
-	224	OFF	OFF	OFF	OFF	OFF	ON	ON	ON
-	225	ON	OFF	OFF	OFF	OFF	ON	ON	ON
-	226	OFF	ON	OFF	OFF	OFF	ON	ON	ON
-	227	ON	ON	OFF	OFF	OFF	ON	ON	ON
-	228	OFF	OFF	ON	OFF	OFF	ON	ON	ON
-	229	ON	OFF	ON	OFF	OFF	ON	ON	ON
-	230	OFF	ON	ON	OFF	OFF	ON	ON	ON
-	231	ON	ON	ON	OFF	OFF	ON	ON	ON

(Continued on next page)

**Table B.** Switch Settings for SW2 (continued)

Receiver Address		Switch Setting							
P-Type	D-Type	SW2-1	SW2-2	SW2-3	SW2-4	SW2-5	SW2-6	SW2-7	SW2-8
Control	Control								
-	232	OFF	OFF	OFF	ON	OFF	ON	ON	ON
-	233	ON	OFF	OFF	ON	OFF	ON	ON	ON
-	234	OFF	ON	OFF	ON	OFF	ON	ON	ON
-	235	ON	ON	OFF	ON	OFF	ON	ON	ON
-	236	OFF	OFF	ON	ON	OFF	ON	ON	ON
-	237	ON	OFF	ON	ON	OFF	ON	ON	ON
-	238	OFF	ON	ON	ON	OFF	ON	ON	ON
-	239	ON	ON	ON	ON	OFF	ON	ON	ON
-	240	OFF	OFF	OFF	OFF	ON	ON	ON	ON
-	241	ON	OFF	OFF	OFF	ON	ON	ON	ON
-	242	OFF	ON	OFF	OFF	ON	ON	ON	ON
-	243	ON	ON	OFF	OFF	ON	ON	ON	ON
-	244	OFF	OFF	ON	OFF	ON	ON	ON	ON
-	245	ON	OFF	ON	OFF	ON	ON	ON	ON
-	246	OFF	ON	ON	OFF	ON	ON	ON	ON
-	247	ON	ON	ON	OFF	ON	ON	ON	ON
-	248	OFF	OFF	OFF	ON	ON	ON	ON	ON
-	249	ON	OFF	OFF	ON	ON	ON	ON	ON
-	250	OFF	ON	OFF	ON	ON	ON	ON	ON
-	251	ON	ON	OFF	ON	ON	ON	ON	ON
-	252	OFF	OFF	ON	ON	ON	ON	ON	ON
-	253	ON	OFF	ON	ON	ON	ON	ON	ON
-	254	OFF	ON	ON	ON	ON	ON	ON	ON



**ThermalVideo.com**  
**Your Source for Modern Thermal Imaging Systems**

P.O. BOX 4242  
 Middletown, NY 10941

PH: + 1 888 919 2263  
 PH Intl: + 1 845 343 4077  
 FX: + 1 845 343 4299  
 support@thermalvideo.com

www.thermalvideo.com