

# ATN Mars 2 ATN Mars 4 ATN Mars 6

## NIGHT VISION RIFLESCOPES



MARS 2/ MARS 4/ MARS 6 OPERATOR'S MANUAL (REV. 4, JUNE 2011)

## *operator's manual*

**Important Export Restrictions!** Commodities, products, technologies and services contained in this manual are subject to one or more of the export control laws and regulations of the U.S. Government and they fall under the control jurisdiction of either the US Department of State or the US BIS-Department of Commerce. It is unlawful and strictly prohibited to export, or attempt to export or otherwise transfer or sell any hardware or technical data or furnish any service to any foreign person, whether abroad or in the United States, for which a license or written approval of the U.S. Government is required, without first obtaining the required license or written approval from the Department of the U.S. Government having jurisdiction. Diversion contrary to U.S. law is prohibited.



**AMERICAN  
TECHNOLOGIES  
NETWORK  
CORP.**

**Register your product warranty online at  
[www.atncorp.com/warranty](http://www.atncorp.com/warranty)**

The information in this manual is furnished for information purpose only, is subject to change without notice, cannot be construed as a commitment by ATN Corp.

ATN Corp. assumes no responsibility or liability for any errors or inaccuracies that may appear in this book.

© 2011 ATN Corp. All right reserved.

# SAFETY SUMMARY

---

## STUDY CAREFULLY THIS MANUAL BEFORE TURNING ON AND OPERATING THIS PRODUCT.

### CAUTIONS

The ATN Mars series night vision scopes are precision electro-optical instruments and require careful handling. Please follow the below instructions of safe use:

- Do not disassemble the scope.
- Keep the scope clean; protect it from moisture, sharp temperature drops and shocks.
- Be careful not to touch the glass surfaces. If you put fingerprints on, or contaminate the glass surfaces, use only clean and soft materials to clean it.
- Protect the scopes from a light overloading. Do not turn the scope on in daylight with the front lens cap off. Do not point the scopes at the bright light source (a fire, car headlights, lanterns, street lamps, room lights, etc.).
- Do not leave the unit in on position during stops in operation.
- Remove the battery from the unit when it is planned to store for over 3 days. Failure to do so may damage the unit.

### NOTES

- Do not test the device in daylight conditions even with the daylight filter/lens cap on for more than ten (10) minutes.
- To protect the device from damage do not direct it to the bright light sources (a fire, headlights of the automobile, lanterns, etc.).

## CAUTION:

**THIS PRODUCT CONTAINS NATURAL RUBBER LATEX WHICH MAY CAUSE ALLERGIC REACTIONS.**

## EQUIPMENT LIMITATIONS

To avoid injuries and equipment damage from using the ATN Mars series, carefully read and consider the following equipment limitations.

- The equipment requires some night light (moonlight, starlight, etc.) to operate. The level of equipment performance depends upon the level of light.
- Night light reduces by passing through the clouds, while operating under trees, under the shadows of houses, etc.
- The device results less effective in peering into shadows and other darkened areas.
- The device results less effective in viewing through rain, fog, sleet, snow or smoke.
- The equipment will not “see” through the dense smoke.
- Its protection system, cuts off the image intensifier when ambient light level continues exceeding of 40 lux for the following 10 seconds.
- Under starlight conditions low contrast environments (such as snow-covered territory, sandy deserts, large bodies of water or grassy hills) degrade visibility thereby disguising or masking changes in terrain.
- Under too low-light conditions the scope loses some of the resolution that it has under full moon.

# TABLE OF CONTENTS

---

	pg.
<b>SAFETY SUMMARY</b>	<b>a</b>
<b>SECTION I. INTRODUCTION</b>	<b>1-1</b>
<b>1.1. General</b>	<b>1-2</b>
1.1.1. Scope	1-2
1.1.2. Reports	1-2
1.1.3. Storage	1-2
1.1.4. Warranty	1-3
<b>1.2. Description and Data</b>	<b>1-5</b>
1.2.1. Description	1-5
1.2.2. Mars Standard Components and Optional Equipment	1-7
<b>SECTION II. OPERATING INSTRUCTIONS</b>	<b>2-1</b>
<b>2.1. Installation Procedures</b>	<b>2-2</b>
2.1.1. ATN Night Vision Riflescopes Mounting System	2-2
2.1.2. ATN Double Lever Quick Release Mount (Optional)	2-3
2.1.3. Long Rail Adapter (Optional)	2-7
<b>2.2. Operating Procedures</b>	<b>2-6</b>
2.2.1. General	2-6
2.2.2. Controls	2-6
2.2.3. Battery Installation	2-10
2.2.4. Operating Procedures	2-8
2.2.5. Automatic Brightness Control	2-9
2.2.6. Highlight Protective System	2-9
2.2.7. Operating at Changing Light Conditions	2-9
2.2.8. Low Battery Indicator	2-10
2.2.9. Focusing	2-10
2.2.10. Remote Control	2-10
2.2.11. IR450 Illuminator	2-11
2.2.12. Reticle	2-13
2.2.13. Windage and Elevation	2-14
2.2.14. Stowage of Mars	2-11

<b>SECTION III. OPERATIONAL DEFECTS</b>	<b>3-1</b>
<b>3.1. Zeroing Operational Defects</b>	<b>3-2</b>
3.1.1. Shading	3-2
3.1.2. Edge Glow	3-3
3.1.3. Flashing, Flickering, or Intermittent Operation	3-3
3.1.4. Cosmetic Blemishes	3-3
<b>SECTION IV. MAINTENANCE INSTRUCTIONS</b>	<b>4-1</b>
<b>4.1. Preventive Maintenance Checks and Services (PMCS)</b>	<b>4-2</b>
4.1.1. Purpose of PMCS	4-2
4.1.2. PMCS Procedures	4-2
<b>4.2. Troubleshooting</b>	<b>4-5</b>
4.2.1. General	4-5
4.2.2. Troubleshooting Procedures	4-5
<b>4.3. Maintenance Procedures</b>	<b>4-7</b>
4.3.1. Mars Maintenance	4-7
4.3.2. Cleaning Procedures	4-7
<b>Appendix A. Estimation of Ambient Illumination Level</b>	<b>A-1</b>
<b>Appendix B. Spare Parts List</b>	<b>B-1</b>
<b>Appendix C. Tube Maintenance/Replacement For Technical Information</b>	<b>C-1</b>
	<b>INFO-1</b>

# **SECTION I**

## **INTRODUCTION**

# **1.1 GENERAL INFORMATION**

---

## **1.1.1. SCOPE**

This manual contains instructions for use in operating and maintaining the ATN Mars series night vision riflescopes. Throughout this manual, the ATN Mars night vision riflescope will be referred to as the scope or the Mars.

## **1.1.2. REPORTS**

Reports from the user on recommendations for improvements are encouraged. Send reports to the address below.

American Technologies Network Corp.  
1341 San Mateo Avenue  
South San Francisco, CA 94080  
(800) 910-2862  
(650) 989-5100  
(650) 875-0129 fax  
[www.atncorp.com](http://www.atncorp.com)  
[info@atncorp.com](mailto:info@atncorp.com)

## **1.1.3. STORAGE**

Storage of the Mars should be done in the factory packing and after a thorough PMCS as outlined in Section 4 of this manual. This will ensure the scope remains in mission ready condition during storage. Battery should be stored separately from the scope.

The Mars should not be placed on the floor, in any area exposed to high temperatures or direct sunlight. Presence of acid and alkaline vapor, as well as of other aggressive admixtures in the air is unacceptable.

## 1.1.4. WARRANTY

### 2 YEAR PRODUCT WARRANTY

This product is guaranteed to be free from manufacturing defects in material and workmanship under normal use for a period of 2 (two) years from the date of purchase. In the event a defect that is covered by the foregoing warranty occurs during the applicable period stated above, ATN, at its option, will either repair or replace the product, and such action on the part of ATN shall be the full extent of ATN's liability, and the Customer's sole and exclusive remedy. This warranty does not cover a product (a) used in other than its normal and customary manner; (b) subjected to misuse; (c) subjected to alterations, modifications or repairs by the Customer or by any party other than ATN without prior written consent of ATN; (d) special order or "close-out" merchandise or merchandise sold "as-is" by either ATN or the ATN dealer; or (e) merchandise that has been discontinued by the manufacturer and either parts or replacement units are not available due to reasons beyond the control of ATN. ATN shall not be responsible for any defects or damage that in ATN's opinion is a result from the mishandling, abuse, misuse, improper storage or improper operation, including use in conjunction with equipment which is electrically or mechanically incompatible with or of inferior quality to the product, as well as failure to maintain the environmental conditions specified by the manufacturer. **CUSTOMER IS HEREBY NOTIFIED THAT OPERATION OF THE EQUIPMENT DURING DAYLIGHT HOURS OR UNDER ANY EXCESSIVE LIGHT CONDITIONS MAY PERMANENTLY DAMAGE THE INTERNAL COMPONENTS OF THE UNIT AND SAID DAMAGE WILL NOT BE COVERED UNDER THIS WARRANTY.** This warranty is extended only to the original purchaser. Any breach of this warranty shall be waived unless the customer notifies ATN at the address noted below within the applicable warranty period.

The customer understands and agrees that except for the foregoing warranty, no other warranties written or oral, statutory, expressed or implied, including any implied warranty of merchantability or fitness for a particular purpose, shall apply to the product. All such implied warranties are hereby and expressly disclaimed.

### LIMITATION OF LIABILITY

ATN will not be liable for any claims, actions, suits, proceedings, costs, expenses, damages or liabilities arising out of the use of this product. Operation and use of the product are the sole responsibility of the Customer. ATN's sole undertaking is limited to providing the products and services outlined herein in accordance with the terms and conditions of this Agreement. The provision of products sold and services performed by ATN to the Customer shall not be interpreted, construed, or regarded, either expressly or implied, as being for the benefit of or creating

any obligation toward any third party of legal entity outside ATN and the Customer; ATN's obligations under this Agreement extend solely to the Customer.

**ATN's liability hereunder for damages, regardless of the form or action, shall not exceed the fees or other charges paid to ATN by the customer or customer's dealer. ATN shall not, in any event, be liable for special, indirect, incidental, or consequential damages, including, but not limited to, lost income, lost revenue, or lost profit, whether such damages were foreseeable or not at the time of purchase, and whether or not such damages arise out of a breach of warranty, a breach of agreement, negligence, strict liability or any other theory of liability.**

## **PRODUCT WARRANTY REGISTRATION**

In order to validate the warranty on your product, ATN must receive a completed Product Warranty Registration Card for each unit or complete warranty registration on our website at [www.atncorp.com](http://www.atncorp.com). Please complete the included form and immediately mail it to our Service Center: ATN Corporation, 1341 San Mateo Avenue, South San Francisco, CA 94080.

## **OBTAINING WARRANTY SERVICE**

To obtain warranty service on your unit, End-user must notify ATN service department by calling **800-910-2862** or **650-989-5100** or via e-mail **service@atncorp.com** to receive a Return Merchandise Authorization number (RMA).

When returning please take or send the product, postage paid, with a copy of your sales receipt to our service center, ATN Corporation at the address noted above. All merchandise must be fully insured with the correct postage; ATN will not be responsible for improper postage or, missing or damaged merchandise during shipment.

When sending product back, please clearly mark the RMA# on the outside of the shipping box. Please include a letter that indicates your RMA#, Name, Return Address, reason for service return, Contact information such as valid telephone numbers and/or e-mail address and proof of purchases that will help us to establish the valid start date of the warranty. Product merchandise returns that do not have an RMA listed may be refused or a significant delay in processing may occur.

Estimated Warranty service time is 10-20 business days. End-user/customer is responsible for postage to ATN for warranty service. ATN will cover return postage/shipping to continental USA end-users/customers after warranty repair only if product is covered by aforementioned warranty. ATN will return product after warranty service by domestic UPS ground and/or domestic mail. Any other requested, required or international shipping method the postage/shipping fee will be the responsibility of the end-user/customer.

## **1.2. DESCRIPTION AND DATA**

---

### **1.2.1. DESCRIPTION**

#### **A. Purpose**

ATN Mars series of Night Vision weapon sights is designed for professional purposes. The series includes scopes with 2.5X (ATN Mars 2), 4X (ATN Mars 4) and 6X (ATN Mars 6) magnification.

Similar to all ATN scopes the ATN Mars features only the purest grades of heavy glass and computer-aided optical designs to create multi-element, high-speed, multi-coated lenses for ultra-fast light transmission and resolution beyond current military standards. All optical lenses on the Mars scopes are individually fitted and calibrated to achieve optimum performance.

#### **B. Principle of Operation**

The Mars operation is based on the principle of electron-optical intensification of light. The input lens collects available ambient light from source such as the moon, stars and sky glow and focuses it on the image intensifier tube photocathode. The tube amplifies the light and produces the viewable image projected from the tube screen to the output lens.

#### **C. Features and Limitations**

The Mars has the following important features:

- Available with 2+, CGT, HPT, 3rd, WPT and 4th generation image intensifier tube.
- Powered by a single CR 123A or AA type battery.
- Adjusts for lens focus.
- Is mounted on MIL-STD-1913/Picatinny rail.
- Equipped with remote control and 450mW IR illuminator.
- Is submersible to 20 m for 1 hour.
- Filled with dry nitrogen to prevent internal fogging.



**FIGURE 1-1. ATN MARS 2 NIGHT VISION WEAPON SIGHT**



**FIGURE 1-2. ATN MARS 4 NIGHT VISION WEAPON SIGHT**



**FIGURE 1-3. ATN MARS 6 NIGHT VISION WEAPON SIGHT**

**TABLE 1-1. SPECIFICATION**

	MARS 2	MARS 4	MARS 6
Generation	2nd+, 3rd, 4th		
Lens of system	F 70; 1:1.5	F 108; 1:1.5	F 160; 1:2.0
Magnification	2.5X	4X	6X
FOV	14 deg.	9 deg.	6 deg.
Range of focus	5 m to ∞	10 m to ∞	25 m to ∞
Eye Relief	45mm		
Exit pupil	7mm		
Diopter adjustment	-5/+5		
Windage & elevation	120MOA	120MOA	80MOA
Adjustment step size	3/8MOA	1/4MOA	1/6MOA
Power supply	one 3V (CR123A) or 1.5V (AA)		
Battery Life	55 hours (3V)/ 40 hours(1.5V)		
Operating Temperature	-51°C to +45°C		
Storage Temperature	-55°C to +70°C		
Waterproof	1m for 30 min		
Reticle	Red on Green		
Dimensions	215x90x85mm	235x90x95mm	295x95x100mm
Weight	1,1 kg	1,3 kg	1,55 kg

The Mars is an effective night vision system designed for night operations but does have following limitations:

- The scope requires some night light (moonlight, starlight, etc.) to operate. Night light is reduced by such factors as passing cloud cover and objects that produce shadows.
- The scope is less effective viewing through rain, fog, sleet, snow, smoke.
- Under starlight conditions low contrast environments (such as snow-covered territory, sandy deserts, large bodies of water

or grassy hills) degrade visibility thereby disguising or masking changes in terrain.

- Under too low-light conditions the scope loses some of the resolution that it has under full moon.

## 1.2.2. MARS STANDARD COMPONENTS AND OPTIONAL EQUIPMENT

The Mars standard components are shown in Figure 4-1 and presented in Table 1-2.



FIGURE 1-4. MARS STANDARD COMPONENTS

TABLE 1-2. MARS STANDARD COMPONENTS

ITEM	DESCRIPTION	QTY
1	Front Lens Cap	1
2	ATN Mars Night Vision Rifle scope	1
3	Mounting System	1
4	Eye Cap	1
5	CR123A type battery	1
6	Remote Control	1
7	IR Illuminator Kit	1
8	Operator's Manual	1
9	Shipping/Storage Case	1

IR Illuminator Kit is shown in Figure 1-5 and listed in Table 1-3.



**FIGURE 1-5. IR450 IR ILLUMINATOR KIT**

**TABLE 1-3. IR450 KIT**

ITEM	DESCRIPTION	QTY
1	IR450-B4 Illuminator	1
2	CR123A type battery	1
3	1.5 mm Allen Key	1
4	IR450 Wrench	1

Optional items are shown in Figure 1-6 and listed in Table 1-4.



**FIGURE 1-6. MARS OPTIONAL EQUIPMENT**

**TABLE 1-4. MARS OPTIONAL EQUIPMENT**

ITEM	DESCRIPTION	ITEM CODE
1	Long Rail Adapter	ACWSLRADPT
2	ATN Double Lever QRM Kit	ACWSMRSXQRM1

ATN Double Lever QRM Kit is shown in Figure 1-7 and listed in Table 1-5.



**FIGURE 1-7. ATN DOUBLE LEVER QRM KIT**

**TABLE 1-5. ATN DOUBLE LEVER QRM KIT**

ITEM	DESCRIPTION	QTY
1	ATN Double Lever QRM Kit	1
2	Screw	2
3	Wrench	1
4	1.5 mm Allen Key	1

## **SECTION II**

# **OPERATING INSTRUCTIONS**

## 2.1. INSTALLATION PROCEDURES

### 2.1.1. ATN NIGHT VISION RIFLESCOPES MOUNTING SYSTEM

The ATN Night Vision Riflescopes Mounting System allows to change the position of the riflescope flexibly on the weapon in relation to a shooter in combination with the fixed positions already available on the weaver rail. For this purpose in the base of the mounting bracket there is a rail with a fixing projection. There are three grooves in the mounting bracket for mounting this rail. Besides it is possible to change the position of the riflescope additionally by 1/3 of inch. For doing this one needs to about-face the rail.

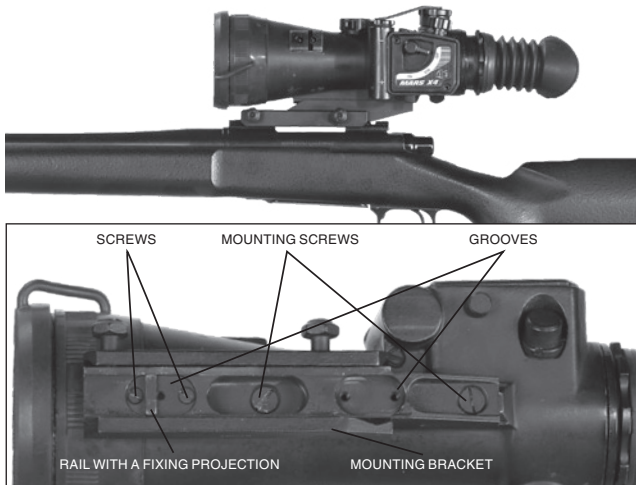

**FIGURE 2-2. SCOPE MOUNTING SYSTEM**

To change the position of the riflescope on the weaver rail additionally follow the steps mentioned below:

1. Unscrew the two screws, which attach the rail to the mounting bracket.
2. Take the rail out of the groove.
3. About-face the rail in case of necessity.
4. Place the rail into another groove.
5. Fix the rail with the two screws.

**NOTE**

If the rail is not taken out easily, screw up tight one of screws into the threaded aperture in the middle of a fixing projection of the rail. Continue rotation of the screw. Thus the screw will push out a rail from a groove.

### 2.1.2. ATN DOUBLE LEVER QUICK RELEASE MOUNT (OPTIONAL)

ATN Double Lever Quick Release Mount (QRM) is used for fast installation/removing the ATN Mars series Night Vision Rifle-scopes on MIL-STD-1913/Picatinny rail.

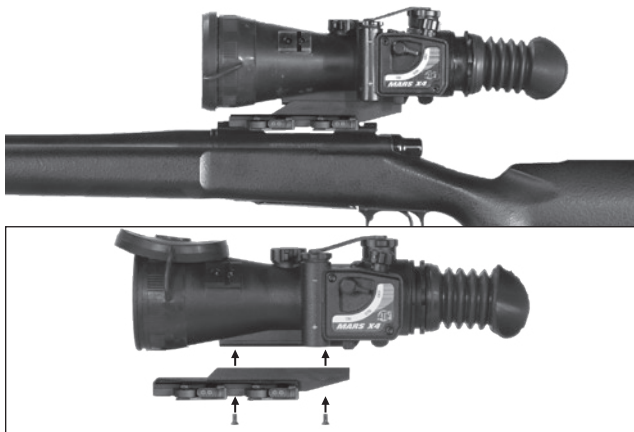

**FIGURE 2-3. DOUBLE LEVER QUICK RELEASE MOUNT**

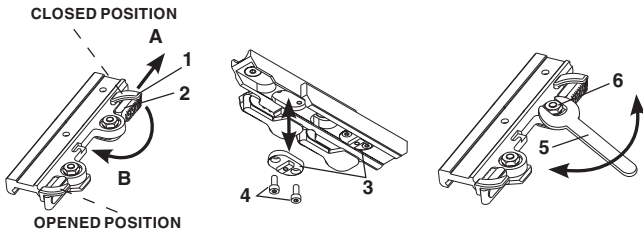

**FIGURE 2-4. DOUBLE LEVER QUICK RELEASE MOUNT ADJUSTMENT**

1. Remove the standard ATN Mounting System from the scope. Unscrew the two mounting screws, which attach the ATN Mounting System to the body of the scope.
2. Mount the QRM onto the scope with two mounting screws.
3. To open the scope QRM, slide the cam latch (1) forward (arrow A) and turn the cam (2) backward (arrow B).
4. Your QRM comes with 2 shoes (3). One for standard weaver rails (designated by the letter W stamped on the shoe) one for MIL-STD-1913/Picatinny rail (designated by the letter P stamped on the shoe). Depending on which rail you are attempting to mount you must remove the other.
5. The shoes can also be adjusted for different mounting positions. To remove shoe unscrew the two screws (4) and place shoe in desired position.
6. Place the scope onto rail. Be sure to engage the recoil lug into the groove on the top mounting surface of the rifle.
7. Turn the cam forward pushing the latch to close the mount.
8. The QRM may be adjusted to eliminate excessive play when mounted on the rail by using the provided wrench (5) to increase/decrease the cam latch nut (6).

### 2.1.3. LONG RAIL ADAPTER (OPTIONAL)

Long Rail Adapter (LRA) is a quick detachable, multiple eye relief mounting base that attaches to weaver type rail and flat-top receivers designed to give flexibility in positioning your Mars upon a firearm with a Picatinny or Weaver rail.

Install the Long Rail Adapter as follows:

1. Loosen the fixing nuts of LRA.
2. Install the LRA onto the weapon mounting rail.
3. Tighten the fixing nuts of LRA tightly.
4. Instal your Mars on the LRA as describe in item 2.1.1



**FIGURE 2-5. MARS ON THE LONG RAIL ADAPTER**

## 2.2. OPERATING PROCEDURES

---

### 2.2.1. GENERAL

This section contains instructions for placing the Mars in operation. The function of controls is explained.

#### **CAUTION**

**The Mars is a precision electro-optical instrument and must be handled carefully at all times.**

### 2.2.2. CONTROLS



**FIGURE 2-5. MARS CONTROLS**

**TABLE 2-2. MARS CONTROLS AND INDICATORS**

CONTROLS	FUNCTION
Operation Switch	STB — the scope is in standby mode.
	OFF — the scope is off.
	ON — the scope is on.
Diopter adjustment ring	Adjusts the grain in the image is sharp.
Focus adjustment knob	Focuses the input lens. Adjusts for sharpest view of scene.
Remote control	Switches the scope from STB to operating mode.
Reticle brightness\ color adjustment knob	Adjusts the reticle brightness\color.
Windage adjustment knob	Horizontal adjustment of reticle.
Elevation adjustment knob	Vertical adjustment of reticle.
Red LED indicator in the FOV	Red glow indicates high light conditions. After 10 seconds the image intensifier will be cut off.
	Flashing red light indicates low battery.

### 2.2.3. BATTERY INSTALLATION

#### **CAUTION**

**Ensure the operation switch is in the off position before installing a battery.**

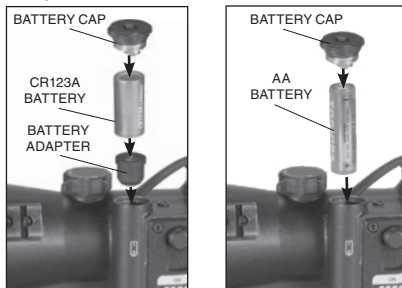

**FIGURE 2-6. BATTERY INSTALLATION**

The ATN Mars operates with one CR123A battery using the battery adapter or one AA type battery without battery adapter.

Install the battery as follows:

Install the battery into its housing with the polarity order shown on the main body of the unit. The CR123A battery used with adapter. Install adapter first, then CR123A. AA battery used without adapter.

## **2.2.4. OPERATING PROCEDURES**

These procedures should be performed under night light conditions only.

### **CAUTION**

**Use of the Mars under high light conditions may damage the image intensifier.**

1. Make sure the battery is installed as indicated on the scope body.
2. Make visual estimation of the illumination level in the viewing area using the reference data presented in Appendix A. You can start to operate with the scope if illumination level is less than 1 lux.
3. Remove the front lens cap.
4. Turn the power switch to the ON position. A green glow will appear in the scope eyepiece (after a slight delay).
5. Observe the scene and adjust focus rotating focusing knob to achieve sharp image.

### **CAUTION**

**Bright sources such as light of fire, headlights, searchlights, etc. can damage the Mars.**

**Take away the Mars from the bright sources that appear on the scene.**

6. Mars shut-down:
  - a) Turn the operation switch to OFF position. The green glow will disappear.
  - b) Replace the protective cover on the input lens.

- c) If necessary remove the scope from the rail in reverse order of installing.
- d) Unscrew the battery cap and take out the battery. Replace the battery cap. Do not store the Mars with the battery still in it.
- e) Return the scope and all accessories to the case.

### **2.2.5. AUTOMATIC BRIGHTNESS CONTROL**

The device has a built-in Automatic Brightness Control. This control automatically adjusts the brightness of Image Intensifier Tube to the optimal level.

### **2.2.6 HIGHLIGHT PROTECTIVE SYSTEM**

The automatic highlight protective system analyses light exposure with the sensor. If the level of light exposure exceeds allowable the red LED indicator in the FOV will light on. If high light exposure is kept more than 10 seconds the device automatically will off. The system works when the sensor cap not cover the light sensor.

#### **NOTE**

**The automatic highlight protective system and automatic brightness control system do not protect a scope from damage by bright light sources (a fire, headlights of the automobile, lanterns, etc.). Do not point the device at a bright light source.**

### **2.2.7. OPERATING AT CHANGING LIGHT CONDITIONS**

If a mission has to be carrying out at changing light conditions, it is possible to shut down the highlight protection system. Close the light sensor with the sensor cap.

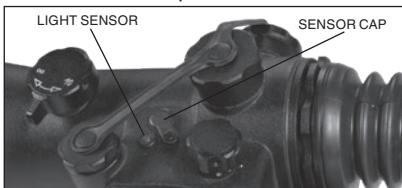

**FIGURE 2-7. LIGHT SENSOR**

## 2.2.8 LOW BATTERY INDICATOR

When red LED in the field of view starts blinking it is time to change your battery.

## 2.2.9. FOCUSING

To focus the scope you need to adjust the diopter ring first. Simply turn the diopter clockwise until it stops. Then concentrate on any object and slowly turn the diopter back counter clockwise until the grain in the image is sharp.

Your scope has ability to focus either long range or short.

Focus the front lens by rotating the knob until the image and the grain are both sharp. When you are in the low-light conditions and the daylight filter is off you may focus the front lens to receive a sharp image, the diopter should not be adjusted.

### NOTE

**The front lens should be readjusted for viewing objects at different distances.**

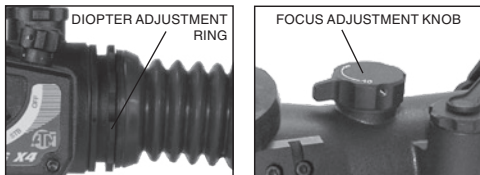

FIGURE 2-8. FOCUSING

## 2.2.10. REMOTE CONTROL

Remote control is designed to operate the Mars in short-time activation mode.

Attach the remote control to the Mars and use it as follows:

1. Remove the plug cap from the plug.
2. Attach the remote control to the plug and secure with the captive nut.
3. Place the remote switch on the fore-end of weapon stock and with Velcro tape.

4. Turn the operation switch in standby position (STB).
5. To activate the scope, press and hold the pressure switch.
6. After disconnecting the remote control, replace the cap onto the connector.

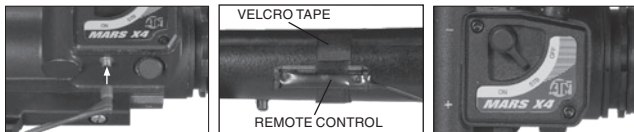

**FIGURE 2-9 . REMOTE CONTROL**

### **2.2.11. IR450 ILLUMINATOR**

Infra-red (IR) Illuminators are common for night vision technology. The IR light greatly enhances the performance of your device, while remaining almost totally invisible to the naked eye. Staying in the dark, switch on your night vision device. If the visibility is low, you may use ATN IR450 to improve the situation. Still, you should remember that the IR illuminator is just a source of infrared light so the greater is the chosen range of observation, the lesser its brightness becomes.

IR450 Infrared Illuminator can be mounted with Mars onto the Pica-tinny Rail.

IR450 Installation:

1. Loosen the fixing nut of IR450.
2. Install the IR450 onto the Picatinny rail.
3. Tighten the fixing nut of IR450 tightly.

The ATN IR450 is powered with one CR123A lithium battery. To install the battery unscrew the cap of the battery housing and insert the battery following the polarity arrows marked on the housing. Put the cap in place.

The IR-450 illuminator has a control panel with two buttons. To switch the IR illuminator on/off press “+” and “-” buttons simultaneously. When the IR illuminator is switched on you can see the green

LED lit on the back side of IR450. By pushing the buttons “+” and “-” you may adjust the IR brightness.

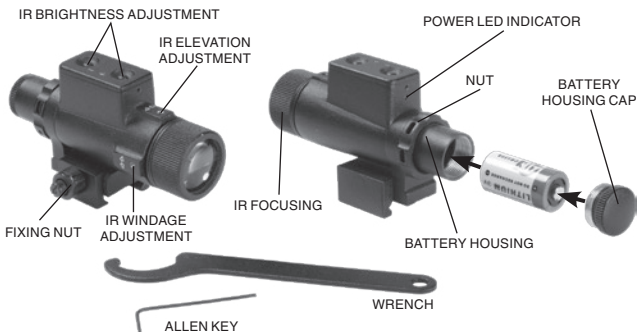
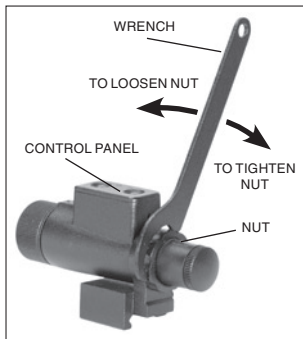

**FIGURE 2-10. IR450 ILLUMINATOR**

The IR beam is focusable to change the field of coverage. To change the beam width slightly turn the IR lens.

You may need adjust the focusing of the IR beam to change the field of coverage. Do it by slightly rotating the IR lens. The windage and elevation screws help adjust the direction of the IR beam from the IR450 in order to focus on the scene observed in the viewfinder of your NVD. Use the included Allen wrench to rotate the adjusting screws until the IR beam is centered. Please remember the adjustments should be performed under night light conditions only.

You can change the position of the IR control panel to meet your your needs. The wrench that is included in the set, is used to



**FIGURE 2-11. CHANGING OF CONTROL PANEL POSITION**

loosen the nut located on the body of the IR. Rotate the IR to the desired position. Tighten the nut with the wrench to secure the new position.

### 2.2.12. RETICLE

Your scope has an electronic reticle with two color and 5 degrees of brightness of illumination for each color. The knob of brightness adjustment reticle and color select is located on the top of the body of the scope. On the knob there are dots marking with color of illumination of reticle.

Mars 2 equipped with chevron rangefinder reticle or crosshair reticle. Mars 4 and Mars 6 have the Mil-dot reticle.

#### Chevron rangefinder reticle

Chevron rangefinder reticle was designed to assist you in determining the range of your target.

These distances are based on a 6' target.

A 6' target fits between the short baselines and the numbered main horizontal line. If the 6' target fits between the 2nd short baseline and the main line the target is 200 yards away. If the same target fits between the 4th short baseline and the main line the target is 400 yards away. The target would be either 100, 300 and 500 yards away.

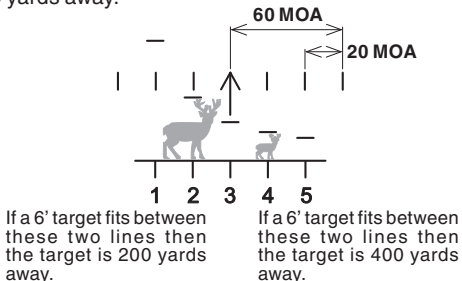

FIGURE 2-12. CHEVRON RANGEFINDER RETICLE

The vertical lines in chevron reticle are proportioned to help in rangefinding and in making allowances for wind or movement.

The size of vertical lines is correspond to 6 feet at 900 yards distance. The horizontal distance between the two lines is correspond to 20 MOA. The vertical size of chevron in the centre of reticle is correspond to 6 feet at 300 yards distance.

### **Crosshair reticle**

Crosshair reticle gives a clearly aiming point, even when hard-to-see game blends into the background. Thinner posts and crosshair center section covers a minimum of the target and allow for less target coverage, making precision shots on small targets easy.

Heavy posts stand out against cover and leads your eye directly to the center intersection. The result is fast precision aiming.

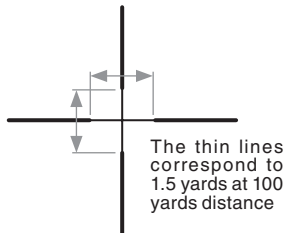

**FIGURE 2-13. CROSSHAIR RETICLE**

### **Mil-dot reticle**

Mil-dot reticle is a reliable means of determining distances to targets, establishing leads for moving targets, and for alternate aiming points for windage and elevation holds.

Dots are spaced in one mil (milliradian) increments on the crosshair. A distance to target can be calculated using the mil formula, that is based on the size of the object being targeted.

Look through the scope, and bracket the object between dots.

The space between dot centers subtends one milliradian (mil). One mil. subtends 3.6 inches at 100 yards or 36 inches at 1,000 yards. To use this system effectively you must know the size of the target.

By measuring the height or width of a known (or approximately known target size) in mil-radians using the reticles, the target distance can be calculated as follows.

R = range in meters, H = target size in meters, M = mil-radians of the image size:

$$R = 1000 * H / M$$

Military shooters are trained to know that the common male torso is 39 inches from crotch to top of head. This is very close to exactly one meter.

This formula then becomes  $R = 1000 / M$  for a one meter target size.

All of the following formulae are equivalent to the one above for estimating range.

R = range in meters, H = target size in inches, M = mil-radians of the image:  $R = 25.4 * H / M$

R = range in yards, H = target size in inches, M = mil-radians of the image:  $R = 27.78 * H / M$

R = range in yards, H = target size in feet, M = mil-radians of the image:  $R = 333.3 * H / M$

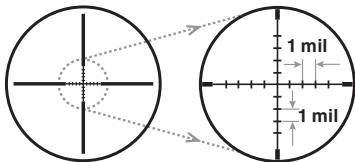

FIGURE 2-14. MIL-DOT RETICLE

### 2.2.13. WINDAGE AND ELEVATION

The vertical and horizontal adjustments for the scope can be achieved by turning the elevation and windage adjustment mechanisms (remove dust caps first). Each click equals 3/8 inch at 100

yards (Mars 2), 1/4 inch at 100 yards (Mars 4) or 1/6 inch at 100 yards (Mars 6) . When reaching the maximum range of rotation do not use force.



**FIGURE 2-15. WINDAGE AND ELEVATION ADJUSTMENT KNOBS**

### **2.2.14. STOWAGE OF MARS**

1. Ensure the Mars and all accessories are clean and dry before returning to storage case.
2. Replace the objective cap and output cap on the lenses. Remove the battery.
3. Make sure the scope and accessories are stored in the appropriate locations in the case and close the cover.

## **SECTION III**

# **OPERATIONAL DEFECTS**

## 3.1. ZEROING OPERATIONAL DEFECTS

---

Operational defects refer to the reliability of the image intensifiers and are an evidence of instability. Their identification shall be a valid reason to immediately refuse to accept the ATN Mars. These include shading, edge glow, flashing, flickering, and intermittent operation.

### 3.1.1. SHADING

If shading is persistent, you will not see a fully circular image (Figure 3-1). Shading is very dark and you cannot see an image through it. Shading always begins on the edge and migrates inward eventually across the entire image area. Shading is a high contrast area with a distinct line of demarcation. Contact ATN or point of purchase for warranty/repair procedures.

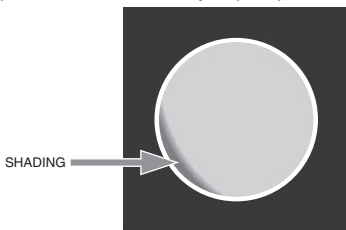

FIGURE 3-1. SHADING

#### **NOTE**

**Make sure the shading is not the result of improper exit pupil position.**

### 3.1.2. EDGE GLOW

Edge glow is a bright area (sometimes sparkling) in the outer portion of the viewing area (Figure 3-2). To check for edge glow, block out all light by cupping a hand over the lenses. If the image tubes are displaying edge glow the bright area will still show up. Contact ATN or point of purchase for warranty/repair procedures.

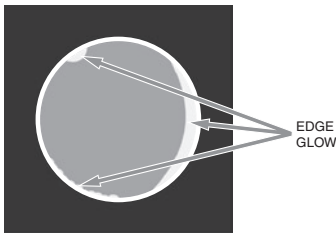

FIGURE 3-2. EDGE GLOW

### 3.1.3. FLASHING, FLICKERING, OR INTERMITTENT OPERATION

The image may appear to flicker or flash. If there is more than one flicker, check for loose battery adapter or weak battery. Contact ATN or point of purchase for warranty/repair procedures.

### 3.1.4. COSMETIC BLEMISHES

These are usually the result of manufacturing imperfections that do not affect image intensifiers reliability and are not normally a reason to claim for warranty or repair work. However, some types of blemishes can get worse over time and interfere with the usability of the device. If you believe a blemish is a cause for rejection, warranty or repair please ATN or point of purchase for warranty/repair procedures.

## A. Bright Spots

A bright spot is a small, non-uniform, bright area that may flicker or appear constant (Figure 3-3).

Not all bright spots make the ATN Mars rejectable. Cup your hand over the lenses to block out all light. If the bright spot remains, return the ATN Mars. Bright spots usually go away when the light is blocked out. Make sure any bright spot is not simply a bright area in the scene you are viewing. Bright spots are acceptable if they do not interfere with the ability to view the outside scene.

## B. Emission Points

A steady or fluctuating pinpoint of bright light in the image area and does not go away when all light is blocked from the objective lenses of the scope (Figure 3-3). The position of an emission point within the image area does not move. Not all emission points make the ATN Mars rejectable. Make sure any emission point is not simply a point light source in the scene you are viewing. Emission points are acceptable if they do not interfere with the usability of the device.

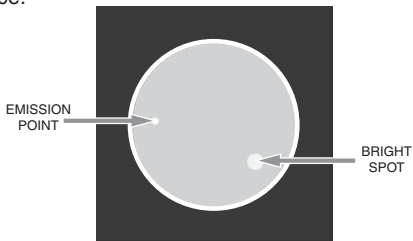

**FIGURE 3-3. BRIGHT SPOTS AND EMISSION POINTS**

### **C. Black Spots**

These are cosmetic blemishes in the image intensifiers or dirt or debris between the lenses. Black spots are acceptable as long as they do not interfere with viewing the image. No action is required if this condition is present unless the spots interfere with the usability of the device.

### **D. Fixed-Pattern Noise**

This is usually a cosmetic blemish characterized by a faint hexagonal (honeycomb) pattern throughout the viewing area that most often occurs at high light levels or when viewing very bright lights (Figure 3-4). This pattern can be seen in every image intensifier if the light level is high enough. This condition is acceptable as long as the pattern does not interfere with viewing the image and usability of the device.

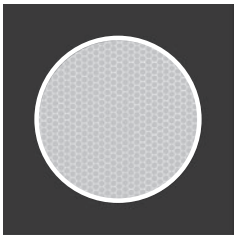

**FIGURE 3-4. FIXED-PATTERN NOISE**

### **E. Chicken Wire**

An irregular pattern of dark thin lines in the field of view either throughout the image area or in parts of the image area (Figure 3-5). Under the worst-case condition, these lines will form hexagonal or square-wave shaped lines. This is typically viewed in high light conditions. No action is required if this condition is present unless it interferes with the viewing the image and interferes with the users usability of the device.

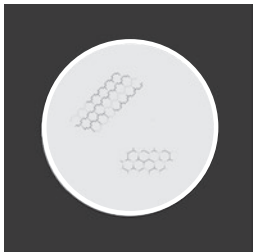

**FIGURE 3-5. CHICKEN WIRE**

## **SECTION IV**

# **MAINTENANCE INSTRUCTIONS**

# 4.1. PREVENTIVE MAINTENANCE CHECKS AND SERVICES (PMCS)

## 4.1.1. PURPOSE OF PMCS

PMCS is performed daily when in use to be sure that the scope is ready at all times. Procedures listed in Table 4-1 are a systematic inspection of the Mars that will enable you to discover defects that might cause the scope to fail on a mission.

## 4.1.2. PMCS PROCEDURES

The frequency of performing PMCS is as follows:

1. Daily when the scope is in use.
2. When it is removed from the case for any reason.

**TABLE 4-1. PREVENTIVE MAINTENANCE CHECKS AND SERVICES**

SEQ. NO.	ITEM TO CHECK	CHECKING PROCEDURE	NOT FULLY MISSION CAPABLE IF:
1	Completeness	Inventory items by means of comparing with the data specified in this manual.	Items missing.
2	Scope Body	Inspect for missing screws or connector cap.	Screws or connector cap missing.
3	Front Lens Cap	Inspect for cuts, tears and dirt. Clean as required.	Cap torn or cut.
4	Eye Cup	Inspect for cuts, tears and dirt. Clean as required.	Cap torn or cut.
5	Lenses	Inspect for cleanliness, scratches, chips or cracks. Clean as required.	Chipped, cracked or if scratches hinder vision through the scope.
6	Battery Compartment	Check for corrosion, springs tension, cap damaged or retainer broken. Check O-ring for cuts or damage.	Springs corroded or damaged. Retainer broken. Cap or O-ring damaged or missing.

**TABLE 4-1. PREVENTIVE MAINTENANCE CHECKS AND SERVICES**

<b>SEQ. NO.</b>	<b>ITEM TO CHECK</b>	<b>CHECKING PROCEDURE</b>	<b>NOT FULLY MISSION CAPABLE IF:</b>
7	Operation Switch	Inspect for broken or missing switch. Check for operation (without battery). Turn the switch from OFF to ON. Each position should have a definite stopping point.	Switch missing. Switch inoperative.
8	Reticle Brightness/Color Adjustment knob	Inspect for broken or missing knob. Check for operation (without battery). Turn the switch from OFF to maximum brightness position. Each position should have a definite stopping point.	Knob missing. Knob inoperative.
9	Focus Knob	Check to ensure: — Inspect for broken or missing knob.; — there is free rotation of the focus ring (more than 1/4 turn).	Focus knob missing. Focus knob cannot be rotated.
10	Remote Control	Check cable and key for damage. Check Velcro tape for wear. Ensure the remote control connects to the scope plug securely.	Cable or key damaged. Velcro tape missing. Connector damage affects ability to connect remote control to the scope.
11	Mounting System	Check for damage or corrosion. Check for proper operation.	Mount body or axles damaged. Fixing nuts or Rail with a fixing projection are missing.
12	Installation security	Check the scope which installed on the arm rail does not have any movement. Tighten fixing nuts if necessary.	

**TABLE 4-1. PREVENTIVE MAINTENANCE CHECKS AND SERVICES**

SEQ. NO.	ITEM TO CHECK	CHECKING PROCEDURE	NOT FULLY MISSION CAPABLE IF:
OPERATIONAL CHECKS			
<p><b>CAUTION</b>  <b>Operate the Mars with Front Lens Cap on or under dark conditions.</b></p>			
13	Operation Switch	Insert the battery. Turn the switch to ON position. Look for green glow in output lens. Turn the switch to OFF position.	Green glow absent.
14	Remote control	Connect the remote control to the scope. Turn the operation switch to STB position. Press and hold the key. Look for green glow in output lens. Release the key; turn the switch to OFF position.	Green glow absent.
15	Viewed Image	Check for flickering, flashing, bright spots, edge glow, shading, excessive fixed-pattern noise (honeycomb).	Excessive cosmetic defects or fixed pattern noise.
<b>AFTER CHECKING PROCEDURES</b>			
16		Replace protective covers to the lenses. Disconnect the remote control and screw up the cap. Remove the battery. Put the scope and all accessories into the storage case.	

## 4.2. TROUBLESHOOTING

---

### 4.2.1. GENERAL

This section contains information for locating and removal most of the Mars operating troubles which may occur. Each malfunction of an individual component or assembly is followed by a list of tests or inspections that will help determine probable causes and corrective action to take. Perform the tests/inspections and corrective actions in the order listed.

This manual cannot list all possible malfunctions that may occur, or all tests or inspections and corrective actions. If a malfunction is not listed (except when malfunction and cause are obvious), or is not corrected by listed corrective actions, contact to the service center.

### 4.2.2. TROUBLESHOOTING PROCEDURES

Troubleshooting procedures are listed in Table 4-2.

**TABLE 4-2. TROUBLESHOOTING PROCEDURES**

<b>PROBLEM</b>	<b>PROBABLE CAUSE</b>	<b>CORRECTIVE ACTION</b>
Scope does not switch on.	Battery is missing or improperly installed.	Insert battery or install correctly.
	Battery is dead.	Replace battery.
	Battery contact surfaces or contact springs are dirty or corroded.	Clean the contact surfaces with a pencil eraser and/or alcohol and cotton swabs.
	Defective image tube.	Send the scope to the service center.
Cannot achieve the sharp image of the object.	Objective and output lenses are dirty.	Clean thoroughly the lenses surfaces.
	Damaged optical components.	Send the scope to the service center.

**TABLE 4-2. TROUBLESHOOTING PROCEDURES**

<b>PROBLEM</b>	<b>PROBABLE CAUSE</b>	<b>CORRECTIVE ACTION</b>
Scope affects boresight after installation or during the firing.	Factory alignment broken.	Send the scope to the service center.
	Loose scope mounting system	Tighten hard the fixing nuts using screwdriver.

## **4.3. MAINTENANCE PROCEDURES**

### **4.3.1. MARS MAINTENANCE**

The Mars maintenance consists of external inspection of its components for serviceability, cleaning and installation of the standard and optional accessories. Maintenance instructions covered elsewhere in this manual (PMCS, troubleshooting, etc.) are not repeated in this section.

#### **CAUTION**

**The Mars is a precision electro-optical instrument and must be handled carefully at all times to prevent damage.**

### **4.3.2. CLEANING PROCEDURES**

#### **A. Cleaning of the Mars**

1. Gently brush off any dirt from the scope body using only a clean soft cloth.
2. Moisten the cloth with fresh water and gently wipe the external surfaces (except lenses).
3. Dry any wet surfaces (except lenses) with another dry and clean soft cloth.
4. Using lens brush, carefully remove all loose dirt from the lenses.
5. Slightly dampen a cotton swab with ethanol and softly and slowly wipe the lenses. Clean the glass surfaces by circular movements from the centre to the edge, not touching the lens holder and changing cotton swab after each circular stroke. Repeat this step until the glass surfaces are clean.

#### **B. Cleaning of Accessories**

Clean accessories with a soft brush (cloth) and soap and water as required.

#### **CAUTION**

**Dry thoroughly each item before replacing into the storage case.**

# APPENDIX A

(Reference)

## ESTIMATION OF AMBIENT ILLUMINATION LEVEL

TABLE A-1. STANDARD NATURAL LIGHT CONDITIONS AND  
ILLUMINATION VALUES

STANDARD NATURAL LIGHT CONDITIONS	ILLUMINATION VALUE, LUX
Quarter moon	0.05
Full moon	0.30
Late twilight sky	1.00
Twilight sky	10.00
Overcast sky in the daytime	500.00

# APPENDIX B

## SPARE PARTS LIST

The Spare Parts List is an illustrated catalog of main parts and assemblies completing the Mars Night Vision Scope.

Therefore, in case of failure of any part or assembly User could replace it by ordering the corresponding part/assembly from the Spare Parts List. The amount and assortment of the spare parts needed should be arranged with each contract individually.

**TABLE B-1. ATN MARS SPARE PARTS LIST**

<b>PART NO.</b>	<b>DESCRIPTION</b>	<b>FIG.</b>	<b>ITEM</b>
<b>AT 146555.700</b>	<b>Night Vision Scope</b>	<b>B1</b>	
AT 146555.701	Front Lens Cap	B1	1
AT 146555.702	Body	B1	2
AT 146555.703	Focusing Knob	B1	3
AT 146555.704	Battery Housing Cap	B1	4
AT 146555.705	Sensor Cap	B1	5
AT 146555.706	Caps Strap	B1	6
AT 146555.707	Dast Cap	B1	7
AT 146555.708	Reticle brightness\color adjustment knob	B1	8
AT 146555.709	Ocular	B1	9
AT 146555.710	Eye cup	B1	10
AT 146555.711	Mounting System	B1	11
AT 146555.717	Rail	B1	12
AT 146555.718	Connector Cap	B1	13
AT 146555.712	Operation Switch	B1	14
AT 146555.713	Battery Adapter	B1	15
AT 146555.714	CR123A Battery Adapter	B1	16

**TABLE B-1. ATN MARS SPARE PARTS LIST**

<b>PART NO.</b>	<b>DESCRIPTION</b>	<b>FIG.</b>	<b>ITEM</b>
<b>AT 146545.700</b>	<b>Accessories 1 (From the Kit)</b>	<b>B2</b>	
AT 146542.710	IR 450 Kit	B2	1
AT 146542.711	Remote Control	B2	2
AT 146545.712	Operator's Manual	B2	3
AT 541002.702	Shipping/Storage Case	B2	4
<b>AT 146556.700</b>	<b>Accessories 2 (Optional)</b>	<b>B3</b>	
AT 146556.751	Long Rail Adapter	B3	1
AT 146556.752	ATN Double Lever QRM Kit	B3	1

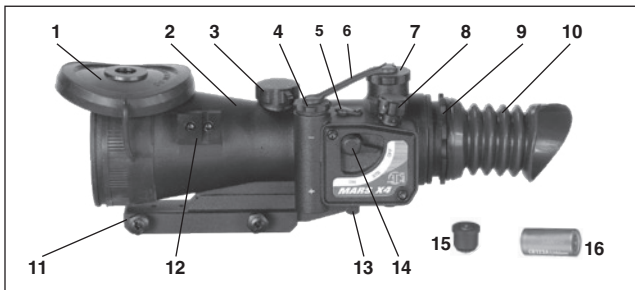

**FIGURE B-1. NIGHT VISION SCOPE**

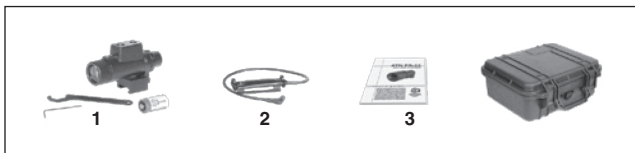

**FIGURE B-2. ACCESSORIES 1 (FROM THE KIT)**

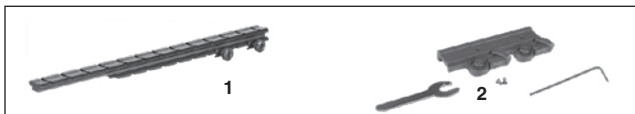

**FIGURE B-3. ACCESSORIES 2 (OPTIONAL)**

# APPENDIX C

## TUBE MAINTENANCE/REPLACEMENT

Tube maintenance/replacement is to be performed by qualified technicians only. These procedures attempted by non-qualified personnel will void warranty.

### C-1. SCOPE DISASSEMBLY

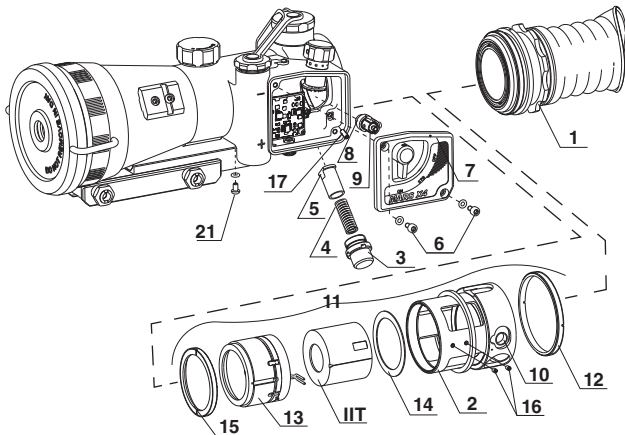

FIGURE C-1. SCOPE DISASSEMBLY

1. Remove Eyepiece (Subassembly 1). Use Eyepiece Wrench ST.T.01.000.
2. Take out the set of insert rings the eyepiece was packed with for safer transportation. The set of insert rings is used instead of Set of Compensation (Cardboard) Rings (2).
3. Screw out Cap (3) using Cap Wrench ST.T.01.001 and draw out Items Spring 4 and Liner 5.
4. Remove Screws (6). Bolt M4 screws into the disposed holes of Screws (6) on the Control Board Cover (7) until it comes apart so you can take it off.

- Loosen Nut (8) of Subassembly (9) (reticle screw) and release reticle screw from Item (10) of Subassembly (11) (Figure C-2).

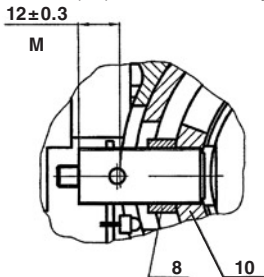

FIGURE C-2

- Use Wrench CT.00.03.000 to take out Thread Ring (12).
- Draw Tube Holder Subassembly (11) out of the scope body.

### C-2. TUBE HOLDER REASSEMBLY WITH TUBE

- Set 37 mm image intensifier tube IIT pre-assembled with IIT Container (13) onto sealant.
- Follow up Figure B3 to calculate the total thickness of the Compensation Ring (14) and trim it.

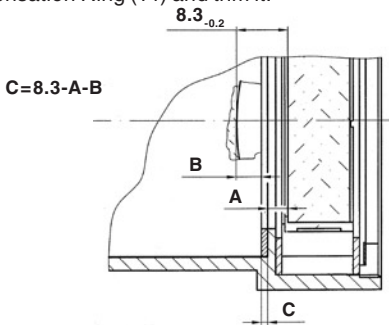

FIGURE C-3

3. Push the trimmed compensation ring, then tube fitted inside the IIT Container into the tube holder. Secure them with Thread Ring 15 (using Wrench ST.00.03.000) and Screws (16) (to arrest the tube transverse offset). Double check Screws (16) are not overtightened! Use primer coat to lock the ring and the screws.

### C-3. ASSEMBLY WORK INSIDE SCOPE

1. First, you will need to calculate the needed thickness of the set of compensation rings.

There are two methods of calculation:

- a) Set collimator and riflescope focus adjustment knob for "infinity" position. Take "D" and "E" measurements (see Figure C4). Push Tube Holder Assembly (11) inside the scope body, first, without compensation rings' set, allowing for 2.5-3mm vacant space from the support lip inside the body which the assembly's end would normally rest against. Solder the IIT Container with the tube inside to the plate. By turning Thread Ring (12) you may smoothly move the tube holder inside the scope body towards the objective lens assembly's location. After the image reaches its grain (in focus), secure this position of the tube holder assembly inside the scope body with Screw (17). Gauge "F" dimension.

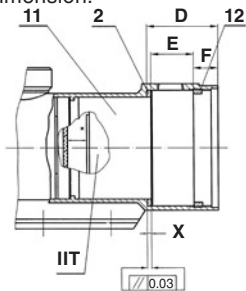

FIGURE C-4

The thickness of the set of compensation rings is deduced from formula:  $X = D - E - F$ .

Loosen the screw, unsolder the tube wires off the plate, and take the tube holder out of the scope body. Trim fit the set of compensation rings for the needed thickness  $X$ .

- b) Assemble the scope with the set of compensation rings 2.5mm thick. The scope focus knob shall be adjusted for “infinity” position. Mount the scope onto a collimating bench. Turn the focus knob until the image reaches its optimal grain (sharpness). Use this position on the collimator scale as a reference point for further calculations. Deduce the needed thickness  $\Delta X$  to trim the set of compensation rings for from the formula below:

$$\Delta X = (F'_{obj})^2 \times [(N_{inf} - N_{opt})/600]^2$$

where:

- $F'_{obj}$  – scope focal distance (108mm or 162mm),
- $N_{inf}$  – collimator scale value for infinity position,
- $N_{opt}$  – collimator scale value for optimal sharpness.

Unsolder the IIT Container wires off the plate. Draw the tube holder assembly out of the body, trim fit the set of compensation rings for the thickness of  $(2.5 - \Delta X)$ mm.

2. Insert the Set of Compensation Rings (2) inside the scope body.
3. Follow up the drawing to install the tube holder assembly and back its position up with Thread Ring (12) using Wrench CT.00.03.000.
4. Install the Liner, the Spring and the Cap (5, 4 and 3). Use Wrench ST.T.00.001 to screw in the cap. Lock the cap with primer coat.
5. Tighten up the Thread Ring (12) and lock it with primer coat.
6. Centerdrill a hole for Screw (17) in the tube holder (11) for 0.5mm deep and coat it with primer.
7. Solder tube wires to the plate.
8. Install Reticle Screw Assembly (5) into Item (10) of Sub-assembly (11) (tube holder). Make sure the reticle crosshair is set

vertically strict and the “M” dimension is provided for (Figure C-2). Secure Subassembly (9) with Nut (8). Lock the nut with primer coat.

9. Install the eyepiece. Secure it with primer coat.

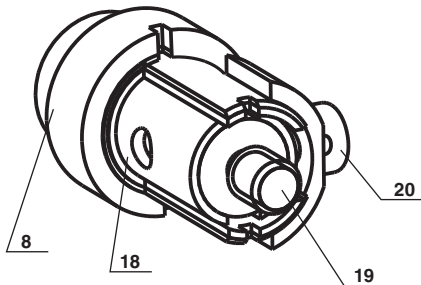

FIGURE C-5

10. Eliminate the parallax between the crosshair plane and the target plane and allow for less than  $1^\circ$  deflection from the parallelism between the vertical reticle crosshair line and the plane that crosses the observation line, vertical. You can achieve it by moving Item (18) with Item (19) of Subassembly (9) (reticle screw ST.01.04.000.SB). Secure this new position with Screw (20) (Figure C-5).
11. Apply sealant to mount the Control Board Cover (7). Lock the Screws (6) with primer coat.
12. Check the air-tightness of the scope with application of 2x104 Pa overpressure (0.2 atm). No pressure drop is acceptable (to inflate air use hole for Screw (21)).
13. Purge the scope internal space with nitrogen of  $-50^\circ\text{C}$  dew point. Then lock Screw (21) with primer coat.

## FOR TECHNICAL INFORMATION

### **ATN CORP.**

1341 San Mateo Avenue  
South San Francisco, CA 94080

(800) 910-2862

(650) 989-5100 tel.

(650) 875-0129 fax

[www.atncorp.com](http://www.atncorp.com)

[info@atncorp.com](mailto:info@atncorp.com)

16052012



For customer service and technical support, please contact  
American Technologies Network Corp.

**North American Office**

1341 San Mateo Avenue, South San Francisco, CA 94080  
phone: 800-910-2862, 650-989-5100; fax: 650-875-0129

**European Office**

The following countries can use our toll free number:

**00 800 9102-8620**

Austria, France, Germany, Holland, Italy, Spain, Sweden, Switzerland

For other countries, please use

**38 048-7770214 or 38 048-7770345**

**[www.atncorp.com](http://www.atncorp.com)**