

ATN PVS-7

NIGHT VISION GOGGLES

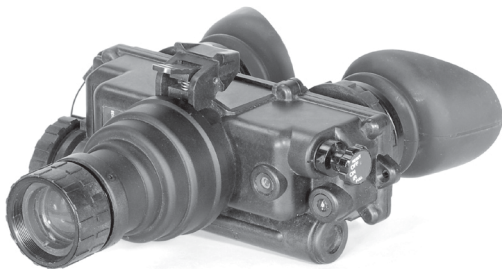

OPERATOR'S MANUAL (PVS-7) REVISION 3 - APRIL 2009

operator's manual

Important Export Restrictions! Commodities, products, technologies and services contained in this manual are subject to one or more of the export control laws and regulations of the U.S. Government and they fall under the control jurisdiction of either the US Department of State or the US BIS-Department of Commerce. It is unlawful and strictly prohibited to export, or attempt to export or otherwise transfer or sell any hardware or technical data or furnish any service to any foreign person, whether abroad or in the United States, for which a license or written approval of the U.S. Government is required, without first obtaining the required license or written approval from the Department of the U.S. Government having jurisdiction. Diversion contrary to U.S. law is prohibited.



**AMERICAN
TECHNOLOGIES
NETWORK
CORP.**

**Register your product warranty online at
www.atncorp.com/warranty**

The information in this manual furnished for information use only, is subject to change without notice, is not to be construed as a commitment by ATN Corp.

ATN Corp. assumes no responsibility or liability for any errors or inaccuracies that may appear in this book.

© 2009 ATN Corp. All right reserved.

SAFETY SUMMARY

CAUTIONS

- *The ATN PVS-7 is a precision optical instrument and should be handled carefully to prevent its damage.*
- *Do not scratch the external lens surfaces or touch them with your fingers.*
- *To protect the image intensifier, keep the lens cap on the objective lens on when the device is not in use or when it is checked out in daylight conditions.*
- *The IR illuminator produces a light that is invisible to a naked eye for use in conditions of extreme darkness. However, this IR light can be detected by somebody else who use a night vision device.*
- *If you use the rubber eyecups for a long time period, you may suffer from skin inflammation. If you find any symptoms, consult a doctor immediately.*

CAUTION:

**THIS PRODUCT CONTAINS NATURAL RUBBER LATEX WHICH
MAY CAUSE ALLERGIC REACTIONS.**

NOTES

- *Do not test the device in daylight conditions even with the daylight filter/lens cap on for more than ten (10) minutes.*
- *To protect the device from damage do not direct it to the bright light sources (a fire, headlights of the automobile, lanterns, etc.).*
- *The purpose of the built-in IR illuminator is to view at close distances up to 3 meters when additional illumination is needed.*
- *The unit is equipped with the Automatic Shut-off System. This system tracks when the unit is not used (the controls are not touched for 60 minutes continuous) and shuts the unit off automatically.*

To turn the unit on after automatic shut off, you need to rotate the operation knob to the OFF position first and then to the ON position.

EQUIPMENT LIMITATIONS

To avoid physical and equipment damage when using the ATN PVS-7, carefully read and understand the following equipment limitations.

- The equipment requires some night light (moonlight, starlight, etc.) to operate. The level of equipment performance depends upon the level of light.
- Night light reduces by passing through the clouds, while operating under trees, at building shadows, etc.
- The equipment is less effective when viewing into shadows and other darkened areas.
- The equipment is less effective when viewing through the rain, fog, sleet, snow or smoke.
- The equipment will not “see” through the dense smoke.

TABLE OF CONTENTS

	pg.
SAFETY SUMMARY	a
CHAPTER 1: Introduction	1-1
Section I: General Information	1-2
1-1 Scope	1-2
1-2 Reporting Equipment Improvement Recommendations (EIR)	1-2
1-3 Glossary	1-2
1-4 Administrative Stowage	1-4
Section II: Equipment Description	1-5
1-5 Equipment Characteristics, Capabilities and Features	1-5
1-6 Equipment Capabilities	1-8
1-7 Specifications	1-8
Section III: Operation principles	1-11
1-8 Mechanical Functions	1-11
1-9 Optical and Electrical Functions	1-12
1-10 Consumable Items	1-13
CHAPTER 2: Operating Instructions	2-1
Section I: Operating Procedures	2-2
2-1 General	2-2
2-2 Controls and Indicators	2-2
Section II: Preventive Maintenance Checks and Services (PMCS)	2-5
2-3 Purpose of PMCS	2-5
2-4 Frequency of Performing PMCS	2-5
2-5 Performance of PMCS	2-5
Section III: Assembly and Preparation	2-10
2-6 Preparation of Use	2-10
2-7 Installation of the Quick Disconnect Helmet Mount Assembly	2-20
2-8 Operating Procedures	2-22
2-9 Preparation for Stowage	2-29

CHAPTER 3: Maintenance Instructions	3-1
Section I: Troubleshooting Procedures	3-2
3-1 Troubleshooting	3-2
Section II: Maintenance Procedures	3-6
3-2 Cleaning the PVS-7	3-6
3-3 Head Mount Maintenance	3-6
APPENDIX A: System Optional Equipment	A-1
FOR TECHNICAL INFORMATION	INFO-1

CHAPTER 1

INTRODUCTION

SECTION I: GENERAL INFORMATION

1-1 SCOPE

This manual provides operation and maintenance instructions for the PVS-7 Night Vision Goggle (which shall be designated a goggle or PVS-7 throughout this manual). The PVS-7 is a self-contained night vision device that enables improved night vision using ambient light from the night sky (moon, stars, sky glow, etc.).

1-2 REPORTING EQUIPMENT IMPROVEMENT RECOMMENDATIONS (EIR)

Reports from the user on recommendations for improvements are encouraged. Send reports to the address below:

American Technologies Network Corp.
1341 San Mateo Avenue
South San Francisco, CA 94080
(800) 910-2862
(650) 989-5100
(650) 875-0129 fax
www.atncorp.com
info@atncorp.com

1-3 GLOSSARY

BLACK SPOTS. These are cosmetic blemishes in the image intensifier of the PVS-7 or dirt or debris between the lenses.

BRIGHT SPOTS. These can be defects in the image area produced by the PVS-7. This condition is caused by a flaw in the film on the micro-channel plate. A bright spot is a small, non-uniform, bright area that may flicker or appear constant. Bright spots usually go away when the light is blocked out and are cosmetic blemishes that are signal induced.

BROWPADS. Three hook-and-pile browpads are provided to adjust the head mount to fit different head sizes. The thin brow pad (fits on a large head) comes attached to the head mount and the thick or medium (fits on a smaller head) brow pads are stored in the carrying case.

CHICKEN WIRE. An irregular pattern of dark thin lines in the field of view either throughout the image area or in parts of the image area. Under the worst-case condition, these lines will form hexagonal or square wave-shaped lines.

DARK (OR DARK AREA). A place in which there is very little light. It does not mean total darkness. Generally, this means conditions similar to a quarter- moon or starlit night.

DEMIST SHIELDS. The two demisting shields are used to prevent the eyepiece lenses from becoming fogged.

DIOPTER. A unit of measure used to define eye correction. Adjustments to the eyepiece focus ring will change diopter and provide a clearer image.

EDGE GLOW. There is a defect in the image area of the PVS-7. Edge glow is a bright area (sometimes sparkling) in the outer portion of the viewing area.

EMISSION POINT. A steady or fluctuating pinpoint of bright light in the image area that does not go away when all light is blocked from the objective lens. The position of an emission point within the image area does not move. An emission point should not be confused with a point light source in the distance.

FIXED-PATTERN NOISE. This is a cosmetic blemish in the image area characterized by a faint hexagonal (honeycomb) pattern throughout the viewing area that most often occurs at high light levels or when viewing very bright lights. Fixed-pattern noise is inherent in the structure of the fiber optics and can be seen in every image intensifier if the light level is high enough.

FLASHING. This is a defect in the image area of the PVS-7 . The image appears to flicker or flash.

FLICKERING. See “flashing”.

IMAGE-INTENSIFIER ASSEMBLY. An electro-optical device that detects and amplifies ambient light to produce a visual image.

INFINITY FOCUS. Adjustment of the objective lens so that a distant object, such as a star or the point light on a distant tower, forms the sharpest image

INTERMITTENT OPERATION. This is a defect in the image area of the PVS-7 . Sec “flashing”.

LIGHT INTERFERENCE FILTER (LIF). This is a tear-protection filter for the goggle. Use of this filter will result in a slight reduction in system gain.

MICROCHANNEL PLATE. A current-multiplying optical disk that intensifies the electron image produced by the photocathode.

PHOTOCATHODE. The input optic of an image intensifier that absorbs light energy and in turn releases electrical energy in the form of an electron image.

SACRIFICIAL WINDOW. A replaceable sacrificial window is supplied to protect the objective lens assembly during operation in adverse conditions.

SCINTILLATION. A faint, random, sparkling effect throughout the image area. Scintillation is a normal characteristic of the image intensifier assembly and should not be confused with emission points. Scintillation is more pronounced under low-light conditions. Also called “video noise”.

SHADING. The viewed image should be a full circle. If shading is present, you will not see a fully circular image. Shading is indicative of a dying photocathode and is caused by a defective vacuum seal of the image intensifier. Shading is very dark and you cannot see an image through it.

1-4 ADMINISTRATIVE STOWAGE

Administrative stowage of equipment should be done in the factory-supplied container and after a thorough PMCS as outlined in Chapter 3 of this manual. This will ensure the PVS-7 remains in a mission ready-condition during storage.

1-5 WARRANTY INFORMATION

This item shall conform to design, manufacturing, and performance requirements and be free from defects in material and workmanship for a period of two (2) years from the date of acceptance. If item is defective, notify ATN or point of purchase contact.

SECTION II: EQUIPMENT DESCRIPTION

1-5 EQUIPMENT CHARACTERISTICS, CAPABILITIES AND FEATURES

The PVS-7 includes the items shown in Figure 1-1. See Table 1-1 and Figure 1-1 for Standard and Optional Equipment.

A. Goggle Assembly. The goggle assembly consists of four primary sub-assemblies; a simple objective lens, a wired housing assembly, an image intensifier tube (IIT) assembly (not shown) and a rear cover assembly. The wired housing assembly contains a built-in battery compartment, attached battery cap and the RESET/OFF-ON-IR/PULL switch.

B. Head mount Assembly. The adjustable, cushioned head mount assembly secures the goggle to the operator's head for night viewing providing freehand support for use with a weapon, protective mask or other purposes. The thin brow pad (used for larger heads) comes attached to the head mount and the thick or medium brow pads (for smaller heads) are stored in the carrying case.

C. Carrying Case. The canvas carrying case is provided for transportation and protection of the PVS-7, head mount assembly, batteries and accessories. Two slide keepers are provided for belt attachment. A carrying case strap is also provided which can be attached to the two D-rings on the back of the carrying case. The case has a zipper closure.

D. Demist Shields. The two demist shields are used to prevent the eyepiece lenses from becoming fogged.

E. Sacrificial Window. A replaceable sacrificial window is supplied to protect the objective lens during operation in adverse conditions.

F. IR Spot/Flood Lens. This item focuses the IR light for a narrow beam (spot) or wide-angle (flood) beam illumination.



Figure 1-1. PVS-7 Components

Table 1-1. System Components

ITEM	DESCRIPTION	PART NO.
1	Head mount Assembly	ATN3144268
2	Thin Brow Pad	ATN3144280
3*	Compass	ATN3187430
4	Medium Brow Pad	ATN3144435
5	Large Brow Pad	ATN3144436
6	Operator's Manual	PVS-OM-007
7	Lens Paper (Not Shown)	-
8	Shoulder Strap Assembly	ATN3144267
9	Light Interference Filter	ATN5009737
10	Sacrificial Window	ATN3144264
11*	IR Spot/Flood Lens	ATN3187441
12*	BA-5567/U lithium battery	
13	Demist Shield Assembly	ATN31442632
14	PVS-7 Assembly	ATN-PVS7-001
15	AA Alkaline Batteries	
16	Carrying Case	ATN3187392
17*	Helmet Mount Assembly	ATN3256390
18	Neck Cord	ATN3260933
19*	Shipping/Storage Case (Not Shown)	ATN3187393
*Optional equipment or Equipment having variants		

G. Compass. This item enables the operator to see azimuth readings in the goggle's illumination viewing area.

H. Neck Cord. This additional authorized item enables the user to attach the compass or 3X magnifier lens to his/her self to guard against dropping or losing these items

I. Optional Equipment. Optional equipment includes demist shields, sacrificial window. Light Interference Filter (LIF), compass, helmet mount assembly and an IR spot/flood lens (see Figure 1-1). Also included is a shipping and storage case. The PVS-7 may be supplied in hard shipping and storage case. Batteries may also be stored in the shipping and storage case.

1-6 EQUIPMENT CAPABILITIES

The PVS-7 is a hand-held, head mounted or helmet mounted night vision system that enables walking, driving, weapon firing, short-range surveillance, map reading, vehicle maintenance and administering first aid in both moonlight and starlight. Each unit allows for vertical adjustment (by using head straps), fore-and-aft adjustment, objective lens focus, eyepiece focus and eye relief distance adjustment. The goggle also equipped with an infrared (IR) light-emitting diode (or illuminator) and a low battery LED indicator. The goggle automatically shuts off when disconnected from the head mount or helmet mount or flipped up on the helmet mount. There is also a high light cutoff feature that shuts off power to the goggle when it is exposed to high levels of light for 70 (± 30) seconds.

1-7 SPECIFICATIONS

The following tables provide information pertaining to the operational, electrical, mechanical, optical and environmental characteristics for the goggles.

Table 1-2. Operator Adjustment Limits

ITEM	LIMITS
Interpupillary Distance	55 to 71 mm
Diopter Focus	+2 to -6 diopters
Objective Focus	25 cm to infinity

Table 1-3. Electrical Data

ITEM	LIMITS
Power Source	Battery (3 VDC max.)
Battery Requirements	2 AA Alkaline or
	1 Lithium (BA-5567/U)

Table 1-4. Mechanical Data

ITEM	LIMITS
Shipping and Storage Case	Size: Approx. 17"x12"x7" Weight: 6.7 lbs.
Soft Carrying Case	Size: Approx. 14"x8"
Goggle (See NOTE)	Weight 1.5 lbs

NOTE

The weight of the PVS-7 does not include accessories.

Table 1-5. Optical Data

ITEM	LIMITS
Magnification	1.0X
Field of View	40°
Eyepiece Focus	+2 to -6 diopters
Focus Range	25 cm (9.8") to infinity

Table 1-6. Environmental Data

ITEM	LIMITS
Operating Temperature	-40°C to +50°C
Storage Temperature	-50°C to +70°C
Illumination Required	Overcast starlight to moonlight
Waterproof	1 meter for 30 min.

SECTION III: OPERATION PRINCIPLES

1-8 MECHANICAL FUNCTIONS

Mechanical adjustments of the PVS-7 allow for physical differences between individual operators using the system. The goggle's functions include the power switch, interpupillary adjustment, release latch, eye relief adjustment, diopter adjustment, IR spot/flood focus (optional), compass illumination (optional), and objective lens focus. The mechanical controls are identified in Figure 1-2.

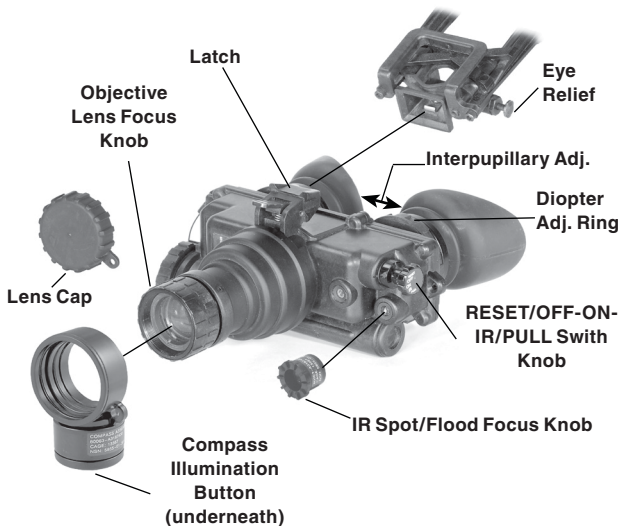

Figure 1-2. Mechanical Controls for PVS-7

1-9 OPTICAL AND ELECTRICAL FUNCTIONS

The optical functions include an objective lens, image intensifier, a collimator lens and two eyepieces. The objective lens collects light reflected from the night scene by the moon, stars or night sky and inverts the image and focuses that image on the image intensifier. The electrical functions include the following.

A. Power Source. The electronic circuit is powered by replaceable batteries - either a 3.0 Volt lithium battery (BA-5567/U) or two AA 1.5 Volt alkaline batteries (BA-305S/U).

B. Electrical Principles. Power from the batteries is supplied to the components through the RESET/OFF-ON-IR/PULL switch as follows:

RESET/OFF Position. With the switch in the OFF position, the circuit is not energized either to the image intensifier or the IR illuminator. Also, turn the switch to this position to reset after automatic shutoff or high light cutoff.

ON Position. Power is drawn from the battery compartment to energize the goggle. When the voltage drops to 2.4 VDC, a low battery indicator at the right eyepiece blinks indicating approximately 30 minutes of operating time.

IR/PULL Position. Power is drawn from the battery compartment to energize the goggle and IR light source and a steady red indicator light in the left eyepiece. The IR is momentarily turned on by turning the switch past ON without pulling the knob.

C. Automatic Shutoff. When the goggle is removed from the head mount or helmet mount while in operation, they will automatically shut off. This prevents enemy detection of the green glow of the image intensifier. To turn the goggle back on, turn the switch to RESET/OFF and then to ON again.

D. High Light Cutoff. The goggle will automatically shut off after 70 (± 30) seconds of operation in daylight or bright room light. Individual bright lights (headlights, flashlights or other concentrated light sources) will not actuate the high light cutoff function unless focused directly on the high light detector located on the front of the

goggle. To turn the goggle back on, turn the switch to RESET/OFF position and then to ON again.

1-10 CONSUMABLE ITEMS

Items listed in the Table 1-7 are recommended for operator maintenance.

Table 1-7. Consumable Items

ITEM	LIMITS
Lens Paper	-
Color Swabs	-
Alcohol	-

CHAPTER 2

OPERATING INSTRUCTIONS

SECTION I: OPERATING PROCEDURES

2-1 GENERAL

This section contains instructions for placing the PVS-7 in operation and to operate it under normal conditions. The function of controls and indicators is explained.

CAUTION

THE PVS-7 IS A PRECISION ELECTRO-OPTICAL INSTRUMENT AND MUST BE HANDLED CAREFULLY AT ALL TIMES.

2-2 CONTROLS AND INDICATORS

The PVS-7 is designed to adjust for different users and corrects for most differences in eyesight. The controls and indicators for the PVS-7 are shown or described in Figure 2-1 and Tables 2-1 and 2-2.

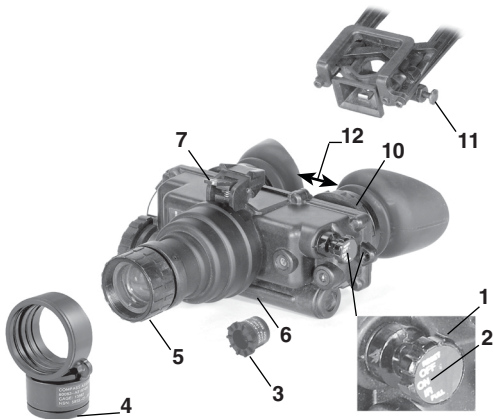

Figure 2-1. PVS-7 Controls and Indicators

Table 2-1. Controls and Indicators

ITEMS	CONTROLS AND INDICATORS	FUNCTIONS
1	RESET/OFF-ON-IR/PULL	<p>Controls goggle and IR light power. ON or OFF.</p> <p>RESET/OFF Same as system OFF. Also resets goggle after automatic shutoff or highlight cutoff.</p> <p>ON Goggle activated.</p> <p>IR/PULL Pull switch out and turn clockwise to activate goggle and IR. Illuminates LED indicator in left eyepiece.</p>
<p>NOTE <i>Some PVS-7's contain an additional momentary IR function. For momentary IR, continue to turn the switch knob clockwise, past ON and without pulling. The switch will return to the ON position when released.</i></p>		
2	RESET/OFF-ON-IR/PULL Label	Defines the switch positions.
3	IR Spot/Flood Lens	Focuses the IR light for a narrow beam (spot) or wide angel (flood) beam illumination.
4	Compass Illuminator Button	Pressing this button activates the compass illuminator LED which makes compass readings visible in the goggle viewing area. Additional pressure will make the image brighter The image disappears when the button is released

ITEMS	CONTROLS AND INDICATORS	FUNCTIONS
5	Objective Focus	Focuses objective lens. Adjusts for sharpest image of viewed object.
6	Battery Polarity Indicator	The feature, molded into the PVS-7, shows the proper orientation of the batteries.
7	Latch	Latch used for separation of goggle assembly from head mount/helmet mount assembly.
8	LED On Indicator (Not Shown)	When illuminated (left eyepiece) it indicates that the IR illumination is on.
9	Low Battery Indicator (Not Shown)	When illuminated (right eyepiece) it indicates a low battery condition with less than 30 minutes of battery life remaining.
10	Diopter Adjustment Ring	Focuses eyepiece lens for each eye without the need for glasses. Adjusts for sharper image of intensifier screen.
11	Interpupillary Adjustment	Adjusts for distance between eyes by sliding the eyepieces either together or apart so each eye can observe the entire field at the same time
12	Eye Relief	Adjusts the distance between your eyes and the goggle.

SECTION II: PREVENTIVE MAINTENANCE CHECKS AND SERVICES (PMCS)

2-3 PURPOSE OF PMCS

PMCS is performed daily when the PVS-7 is in use to ensure that the sight is ready at all times. Procedures are a systematic inspection of the goggle that will enable you to discover defects that might cause the PVS-7 to fail on a mission.

2-4 FREQUENCY OF PERFORMING PMCS

The frequency of PMCS performing PMCS is follows:

A. Daily when the PVS-7 is in use.

B. Weekly when in a standby condition.

C. Semi-annually when stored in depot or administrative storage.

2-5 PERFORMANCE OF PMCS

Preventive maintenance checks and services shall be performed following the sequence and inspection procedures indicated in Table 2-2

Table 2-2. Preventive Maintenance Checks and Services

B = Before Operation; D = During Operation; A = After Operation

INTERVAL & SEQUENCENO			ITEM TO BE INSPECTED/ PROCEDURE
B	D	A	
1			GOGGLE - Check for completeness, including accessories. Check for dirt and moisture on external surfaces and parts. Clean and dry with lint-free cloth.
2			SHIPPING CASE - Check for dirt, moisture and mildew. Clean with mild detergent and water. Dry with lint-free cloth.

INTERVAL & SEQUENCENO			ITEM TO BE INSPECTED/ PROCEDURE
B	D	A	
3			CARRYING CASE - Check for dirt, moisture and mildew. Clean with mild detergent and water. Dry with lint-free cloth.
4			BATTERIES - Remove batteries. Check for corrosion on terminals and dirt or moisture in battery cap. Clean battery cap with dry cloth. Replace batteries if corroded.
5			LENSES - Check for dirt and moisture. Clean with lens paper or brush and/or alcohol and cotton swabs
6			EYECUPS - Check for dirt, dust, cracked or torn cups. Inspect for bent, broken or improperly fitting eyecup.
7			INTERPUPILLARY ADJUSTMENT - Slide each eyepiece back and forth to check for binding or looseness.
8			OBJECTIVE LENS FOCUS KNOB - Rotate objective lens focus knob to ensure free movement (range is approximately 1/3 turn).
9			NECK CORD & LENS CAP- Check for cracked, torn or missing lens cap. Inspect cord for cuts, damage or frayed ends. Re-tie ends if necessary.
10			LATCH - Inspect for damage.

INTERVAL & SEQUENCENO			ITEM TO BE INSPECTED/ PROCEDURE
B	D	A	
11			RESET/OFF-ON-IR/PULL SWITCH - Remove any batteries and turn the switch from RESET/OFF to ON or IR/PULL. Each position should have a definite stopping point. Inspect for broken or missing knob.
HEAD MOUNT			
12			STRAPS AND PADS - Check for cuts tears, fraying, holes, cracks or defective fasteners.
13			SOCKET - Check for dirt, dust or corrosion. Insert goggle latch into socket to verify secure attachment of goggle to head mount. If necessary, clean socket with water.
14			FORE-AND-AFT ADJUSTMENT - Press the socket-release button and check for free motion. Inspect for damage.
OPTIONAL HELMET MOUNT			
15			STRAPS - Inspect for cuts; tears: fraying; holes cracks or defective fasteners
13			SOCKET - Check for dirt, dust or corrosion. Insert goggle latch into socket to verify secure attachment of goggle helmet mount. If necessary, clean socket with water.
17			FORE-AND-AFT ADJUSTMENT - Press the socket-release button and check for free motion. Inspect for damage.
18			FLIP-UP/AUTO OFF - With goggle on, flip-up and verify auto off function operation.

INTERVAL & SEQUENCENO			ITEM TO BE INSPECTED/ PROCEDURE
B	D	A	
19			TILT ADJUSTMENT - Verify knob locks tilt in place and full range of tilt is available with knob loosened.
20			SOFT CARRYING CASE - Remove all items and shake out loose dirt or foreign material. Inspect for tears, cuts, excess wear or damage to mounting clips.
21			SHOULDER STRAP ASSEMBLY - Inspect for cuts, tears or excess wear of damaged clips.
<p>NOTE <i>Damaged optional items (compass, IR spot/flood, sacrificial window, demist shields) do not cause the entire end item to be "not fully mission capable". However, the damaged item should be replaced as soon as practical to restore full capability of the system.</i></p>			
ACCESSORY ITEMS			
22			DEMIST SHIELDS - Inspect for dirt, dust scratches or damage. If necessary, clean when shields are dry and with dry lens paper only.
23			LIGHT INTERFERENCE FILTER (LIF) - Inspect for dirt dust, scratches or damage. If necessary, clean with water and dry with lens paper.
24			IR SPOT/FLOOD LENS - Rotate IR focus lens to ensure free movement.

INTERVAL & SEQUENCENO			ITEM TO BE INSPECTED/ PROCEDURE
B	D	A	
25			COMPASS ASSEMBLY - Inspect for dirt, dust scratches or damage. If necessary, clean with water and dry with lens paper. Install compass assembly and turn on goggle. When the illumination button is depressed, the compass should be visible.
26			3X/5X AFOCAL MAGNIFIER LENS - Check lens for scratches or damage. Check mating to objective lens by screwing in or pressing on with adapter installed.

SECTION III: ASSEMBLY AND PREPARATION

2-6 PREPARATION FOR USE

This chapter contains the information necessary to prepare the goggle for operation. This includes unpacking, examination for goggle damage, battery installation, sacrificial window installation and head mount installation and adjustments.

A. Unpacking. The following steps must be accomplished prior to each mission where the PVS-7 is used.

CAUTION

RELIEVE AIR PRESSURE INSIDE SHIPPING AND STORAGE CASE BY PRESSING RELIEF VALVE BUTTON LOCATED NEAR THE CARRYING CASE HANDLE BEFORE RELEASING LATCHES.

1. Release the two latches securing top of shipping and storage case and open top.
2. Check contents of shipping and storage case for completeness. (see Figure 1-1.)
3. Remove the carrying case from the shipping and storage case. Open carrying case (Figure 1-1), remove the PVS-7 and check contents for completeness.
4. Inspect the goggle for obvious evidence of damage to optical surfaces, body, eyecups. RESET/OFF-ON-IR/PULL switch, battery cap, etc. Ensure that all optical surfaces are clean and ready for use. Clean with lens paper.

B. Installation of Batteries.

CAUTION

TO PROTECT THE IMAGE INTENSIFIED KEEP THE LENS CAP ON THE OBJECTIVE LENS WHEN THE GOGGLE IS NOT IN USE OR WHEN CHECKED OUT IN DAYLIGHT CONDITIONS.

NOTE

Operation of the PVS-7 under daylight conditions will activate the high light cut off in 70 (± 30) seconds, causing the goggle to shutdown.

WARNING

THE LITHIUM BATTERY CONTAINS SULFUR DIOXIDE GAS UNDER PRESSURE.

DO NOT HEAT, PUNCTURE, DISASSEMBLE, SHORT CIRCUIT, ATTEMPT TO RECHARGE OR OTHERWISE TAMPER WITH THE BATTERIES.

TURN OFF EQUIPMENT IF BATTERY COMPARTMENT BECOMES UNDULY HOT. IF POSSIBLE, WAIT UNTIL THE BATTERIES HAVE COOLED BEFORE REMOVING THEM.

BATTERIES HAVE SAFETY VENTS TO PREVENT EXPLOSION. WHEN THEY ARE VENTING GAS, YOU WILL SMELL IT (VERY-IRRITATING) OR HEAR THE SOUND OF GAS ESCAPING. WHEN THE SAFETY VENTS HAVE OPERATED, THE BATTERIES ARE FAIRLY SAFE FROM BURSTING, BUT STILL MUST BE HANDLED WITH EXTREME CARE BECAUSE OF HEAT.

IF YOU INHALE SULFUR DIOXIDE, SEEK MEDICAL ATTENTION.

The PVS-7 will operate with either of the two battery types identified in Table 2-3. Batteries are not supplied with the PVS-7 and must be obtained.

Table 2-3. Estimated Battery Life

BATTERY TYPE	NEGLIGIBLE IR USAGE	IR USAGE 10% OF THE TIME
Lithium (BA-5567/U)	47-85 Hours	36 - 65 Hours
AA Alkaline (BA-3058/U)	89-160 Hours	68 - 123 Hours

NOTE

The battery data in Table 2-3 represents operation under room temperature. When operating under cooler conditions, battery life will decrease.

CAUTION

MAKE CERTAIN THE RESET/OFF-ON-IR/PULL SWITCH IS IN THE OFF POSITION BEFORE INSTALLING BATTERIES.

Install either two (2) AA batteries or one (1) BA-5567/U lithium battery as follows. Do not attempt to mix battery types in the compartment.

1. Remove the battery cap by turning it counterclockwise.
2. Check to ensure the o-ring is present. If not, replace it.
3. Observe polarity, as indicated on the outside of the battery compartment, and insert either two AA, 1.5 Volt batteries or one 3.0 Volt BA-5567/U lithium battery into the battery compartment, plus (+) end first. (See Figure 2-2.)
4. Replace battery cap by pushing and turning it clockwise. Tighten it firmly to ensure a watertight seal.

C. Installation of the Eyecups. Perform the following procedure to install the eyecups onto the PVS-7. Refer to Figure 2-2.

1. Carefully press each eyecup over the diopter cell retainer.
2. Rotate each eyecup into proper viewing position. Adjust for best eye fit. The eyecups must seal around your eyes and prevent the green glow from escaping.

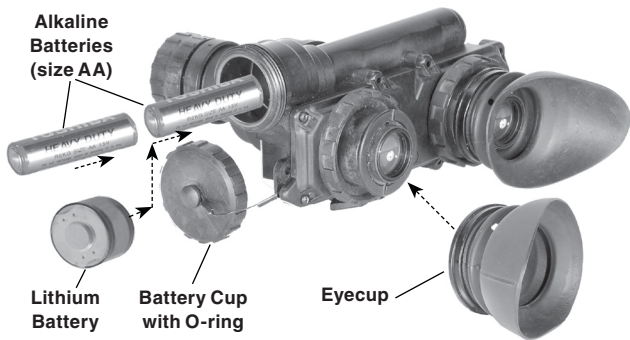

Figure 2-2. Battery and Eye cap Installation

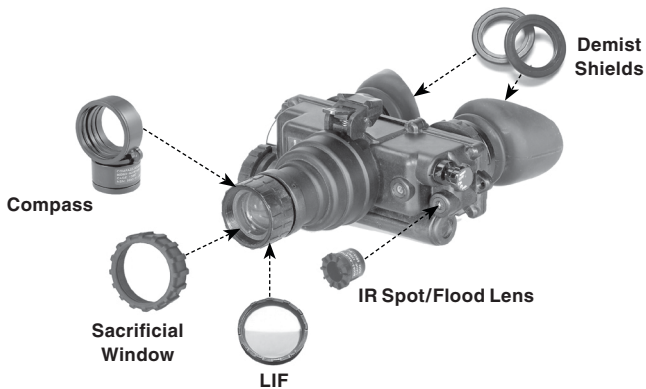

Figure 2-3. Installation of Demist Shields, Sacrificial Window

D. Installation of the Demist Shields. Perform the following procedure to install the demist shields on the diopter lenses. Refer to Figure 2-3.

CAUTION

IF THE DEMISTING SHIELDS NEED TO BE CLEANED, MAKE SURE THE SHIELDS ARE DRY AND USE DRY LENS PAPER. IF THE DEMIST SHIELDS ARE WIPED WHILE WET OR WITH WET LENS PAPER, YOU WILL DAMAGE THE COATING.

NOTE

If inclement operating conditions are known to exist (e.g. significant temperature change and high humidity), install the demist shields to minimize diopter lens fog prior to execution of mission.

1. Carefully remove the eyecups.
2. Carefully press a demist shield onto each eyepiece. Be careful not to smudge the eyepieces or demist shields.
3. Replace the eyecups (see paragraph 2-6, C).

E. Installation of the sacrificial Window. Perform the following procedure to install the sacrificial window. Refer to Figure 2-3.

CAUTION

IF ADVERSE OPERATING CONDITIONS (DUST OR SAND), ARE KNOWN TO EXIST, ATTACH THE SACRIFICIAL WINDOW TO PROTECT THE OBJECTIVE LENS FROM SCRATCHES OR OTHER DAMAGE.

1. If the compass assembly or lens cap is in place, remove it.
2. Carefully push the sacrificial window over the objective lens until it stops. Turn the sacrificial window clockwise until it snaps into place.

F. Installation of the Compass Assembly.



Figure 2-4. Installation of Compass

NOTE

- a. Prepare the PVS-7 for operation (paragraph 2-6).
- b. Leave LIF in place when installing the compass assembly.
- c. Ensure the Neck cord is secured to the compass and clothing before installing.

1. If the sacrificial window or lens cap is in place, remove it.
2. Turn the PVS-7 on.
3. Rotate the objective lens focus completely counterclockwise (while looking through the goggle).

4. Press the compass assembly onto the objective lens at an angle using your left hand. Slowly turn the compass assembly counterclockwise until it is in the vertical position (with compass illumination button pointing down). See Figure 2-3.

5. Ensure that the compass fits tightly to the PVS-7.

NOTE

The o-ring must be in place in the compass assembly in order for the compass to fit properly.

6. Refer to paragraph 2-6, F for operation of the compass.

G. Installation of the Light Interference Filter. Perform the following procedure to install the light interference filter (LIF) onto the objective lens assembly.



Figure 2-5. Installation of the Light Interference Filter

1. Remove the container/wrench from the carrying case pouch.).
2. If the lens cap, compass assembly, or sacrificial window is on the objective lens of the PVS-7, remove it.
3. Carefully open the container/wrench and remove the LIF.
4. Hold the LIF by the notched end and thread it clockwise into the end of the objective lens (see Figure 2-5).
5. Using the ridged side of the container/wrench as a wrench, engage the ridges on the container with the ridges on the LIF and tighten the LIF hand tight.
6. Place the empty container/wrench back into the pouch in the carrying case.

7. Replace the lens cap or the sacrificial window onto the end of the objective lens and over the LIF.

CAUTION

BE CAREFUL NOT TO TOUCH THE GLASS SURFACES. IF YOU GET FINGERPRINTS OR CONTAMINATION ON THE GLASS SURFACES, USE LENS PAPER TO CLEAN THE LIF. IF MOISTURE IS NEEDED, USE YOUR BREATH TO MIST THE SURFACE OF THE GLASS.

DO NOT OVER-TIGHTEN THE LIF INTO THE OBJECTIVE LENS.

NOTE

The lens cap, compass assembly, or the sacrificial window will fit onto the end of the objective lens with the LIF in place.

H. Installation of the IR Spot/Flood Lens.

1. Press the IR spot/flood lens over the IR source until it is tight against the goggle. Refer to Figure 2-6.

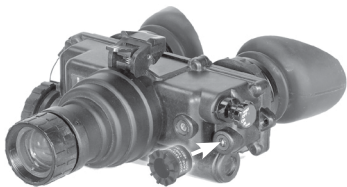

Figure 2-6. Installation of the IR Spot/Flood Lens

I. Installation and Adjustment of the Head Mount Assembly.

Perform the following procedures for donning the head mount.

NOTE

Do not don the head mount while the PVS-7 is attached to it.

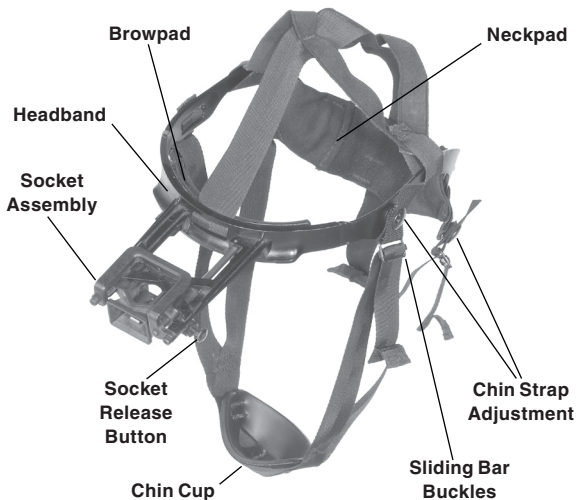

Figure 2-7. PVS-7 Head Mount Adjustments

1. Prior to donning the head mount, loosen the four chin straps so the ends of each strap arc approximately two inches from the sliding bar buckles (See Figure 2-7)
2. Snap the front and rear snaps in place.

NOTE

If the head mount is too loose, remove the attached thin brow pad and replace with either the medium or large brow pad, stored in the carrying case. Refer to Chapter 3, paragraph 3-4 for removal and replacement of the brow pads.

3. With both hands, grasp the neck pad assembly and pull the harness over your head and the neck pad down to the back of your neck.

4. Holding the chin cup in position on chin, adjust both rear chin cup assembly straps until you feel light pressure against your chin. (DO NOT TIGHTEN).
5. Maintain the position of the chin cup and remove any slack from the front and rear chin straps. (DO NOT TIGHTEN).
6. Ensure that the cross-strap assembly is not twisted and remove slack by adjusting the vertical adjustment strap at the neck pad.
7. Adjust chin strap and vertical adjustment until the chin cup and headband assembly arc in comfortable but firm position.

NOTE

After installing the PVS-7, minor strap adjustments may be necessary to achieve comfort.

8. Refer to paragraph 2-7, A for operating procedures of head mount assembly.

J. Installation of Head Mount Assembly with Protective Mask.

Perform the following procedures for donning the head mount with a protective mask.

1. Place protective mask on your head per the instructions provided with the mask.

WARNING

WHEN INSTALLING THE HEAD MOUNT OVER THE PROTECTIVE MASK, BE CAREFUL NOT TO BREAK THE PROTECTIVE MASK SEAL AROUND YOUR FACE.

2. Install the head mount assembly per instructions in paragraph 2-6, I.

NOTE

It may be necessary to remove the brow pad when wearing the head mount over a protective mask.

K. Installation of the Head Mount Assembly with the PASGT Helmet. Install the head mount assembly per the instructions in paragraph 2-6, I.

L. Installation of the Head Mount Assembly with the M1 Helmet. Install the head mount assembly per the instructions in paragraph 2-6, I.

M. Installation of the Helmet Mount Assembly (Optional) to the PASGT Helmet.

1. Remove mount assembly from the carrying case. Refer to Figure 2-8 for the helmet mount features.

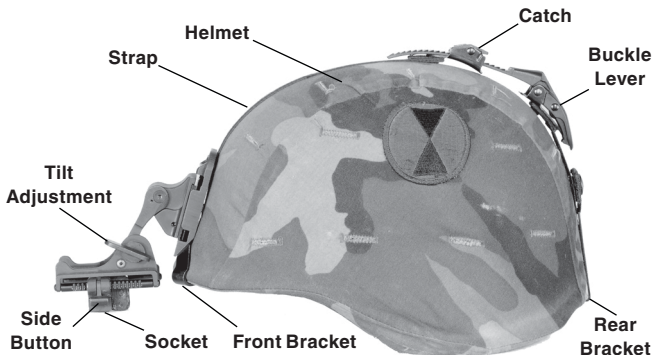

Figure 2-8. Helmet Mount Features

2. With the catch in forward most position, place the strap over the top of the helmet, center and hook the rear bracket onto the rear of the helmet. Center the front bracket, hook in on the front of the helmet and hold it in place. (See Figure 2-8.)

3. With the buckle-lever open, take up the slack in the strap using catch. Close the buckle lever.

4. Place the helmet upside down with the helmet mount facing you.

NOTE

Steps 5 and 6 describe the installation of the nape strap to the chin-strap. To accomplish these steps, it may be necessary to unthread the chinstrap from the helmet.

5. Thread the chinstrap through the right end of nape strap and snap nape strap fastener tab closed. (Refer to Figure 2-9.)

6. Thread chin strap through the left end of nape strap and snap nape strap fastener tab closed. (Refer to Figure 2-9.)

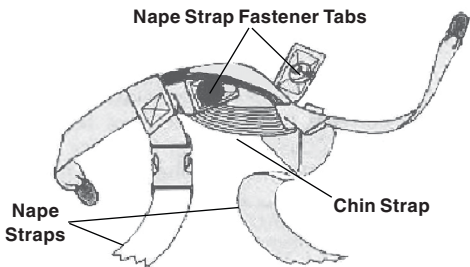

Loop the nape strap fastener tabs around the corners of the chin strap and snap closed. After closure, the snaps will be on the outside, away from your chin.

Figure 2-9. Nape Strap Installation

7. Disengage the nape strap latch on the left side of the nape strap.
8. Don the helmet.
9. Engage the nape strap at the nape strap latch. Tension the chin-strap and nape strap for a secure and stable fit. The brow of the helmet should be parallel with the ground.

2-7 INSTALLATION OF THE QUICK DISCONNECT HELMET MOUNT ASSEMBLY

1. Remove the helmet mount assembly from the carrying case. Make sure the helmet mount is complete. Refer to Figure 2-10 for the helmet mount components and features.

CAUTION

TO PREVENT POSSIBLE EQUIPMENT DAMAGE, REMOVE BOTH THE GOGGLES AND THE MOUNT ASSEMBLY FROM THE HELMET WHEN NOT REQUIRED FOR IMMEDIATE USE. THE CLIP/STRAP ASSEMBLY CAN REMAIN IN PLACE ON THE HELMET.

2. If the mount assembly and clip/strap assembly are connected, remove the mount assembly. To do this, push the release lever at the top center of the mount and slide the two assemblies apart.
3. Adjust the clip/strap assembly to fit the helmet size being used.
4. With the catch in the most extended position, place the strap over the top of the helmet, center and hook the rear bracket onto the rear of the helmet. Center the front bracket hook on the front of the helmet and hold it in place.
5. With the buckle lever open, take up the slack in the clip/strap assembly using the catch. Close the buckle lever.
6. If the PASGT helmet has its cloth cover and camouflage strap installed, it will be necessary to slide the camouflage strap up (at about a 30°-45° angle) at the front of the helmet (see Figure 2-10).

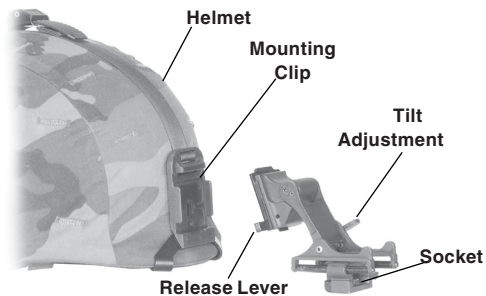

Figure 2-10. Quick Disconnect Helmet Mount Features

7. Disengage the nape strap latch on the left side of the nape strap.
8. Don the helmet. Do not fasten the helmet chinstrap.
9. Engage the nape strap at the nape strap latch. Tension the nape strap for a stable fit, then install and tension the helmet chin-strap. The brow of the helmet should be parallel to the ground and the helmet stable on the head.
10. To install the mount assembly into the clip/strap assembly, place its top flange to the top groove of the mounting clip and then

press to the mount assembly bottom until it locks into place with a click (see Figure 2-10).

2-8 OPERATING PROCEDURES

This section contains operating procedures for using the PVS-7 as a hand-held, head mounted or helmet mounted goggle. Prior to operating the goggle, ensure that all the steps in paragraph 2-6 have been read and performed.

A. Head Mounted Operation. Perform the following procedures for head mounted operation.

CAUTION

OPERATE THE PVS-7 ONLY UNDER DARKENED CONDITIONS OR USE THE LENS CAP TO COVER THE OBJECTIVE LENS FOR DAYLIGHT CONDITIONS.

NOTE

Proper objective focus cannot be obtained while the objective lens cap with pinhole is covering the objective lens. Proper objective focus must be done in the dark with the objective lens cover removed.

1. Ensure that the batteries are installed per paragraph 2-6, B.
2. Don the head mount per instructions in paragraph 2-6, I.

NOTE

Paragraphs 2-6, J, 2-6, K and 2-6, L provide additional information required when installing the head mount with a protective mask, PASGT or M1 helmet.

To make it easier to align the goggle, eyecups and diopter eyepieces to the eyes, depress the socket-release button (See Figure 2-8) and slide the head mount socket all the way forward before attaching the goggles.

3. Align the PVS-7 's latch (Figure 2-1) to the head mount socket (See Figure 2-8). Press and hold down the latch lever while installing the goggle into the head mount socket. Release the latch when the goggle is fully engaged in the socket.

4. Set your eye relief by depressing the socket-release button and move the PVS-7 back toward your eyes until the eyecups comfortably seal around your eyes.
5. Turn the RESET/OFF-ON-IR/PULL switch ON.
6. Adjust the interpupillary distance (Figure 2-1) by sliding the eyepieces together or apart so each eye can observe the entire field of view at the same time. The eyepieces adjust independently.
7. Readjust the vertical strap assembly (see Figure 2-7) for vertical adjustment of the head mount until the PVS-7 is properly aligned with your eyes.

NOTE

The sharpest image will be observed only when the objective lens and both eyepieces are properly focused. The objective lens focus adjustment is used to focus on objects at varying distances. The diopter adjustment rings are used to focus your eyes (without glasses) on the image intensifier screen. These adjustments operate independently and must be made separately.

8. Fold the right eyecup over the eyepiece with your right thumb or forefinger to obstruct the view through the right eyepiece. Rotate the left diopter adjustment ring for the clearest view of the image intensifier screen.
9. Fold the left eyecup over the eyepiece with your left thumb or forefinger to obstruct the view through the left eyepiece. Rotate the right diopter adjustment ring for the clearest view on the image intensifier screen.
10. Adjust the eye relief distance by pressing the socket release button (See Figure 2-1) and sliding the PVS-7 fore or aft to obtain a full field of view of the image. Readjust the diopter rings for best image.

NOTE

Any readjustment of eye relief requires readjustment of the diopter rings.

11. Adjust the objective lens focus (Figure 2-1) while observing an object until the sharpest image is obtained.

B. Helmet Mounted Operation. Perform the following procedures for helmet mounted operation.

1. Ensure that batteries are installed per paragraph 2-6, B.
2. Don the helmet mount per instructions in paragraph 2-6, M.
3. Place the PVS-7 in the socket of the helmet mount. (See Figure 2-8.) Set your eye relief by depressing the side buttons and carefully move the goggles fore or aft until the eyecups comfortably seal around the eyes. Readjust the helmet straps as required for vertical adjustment.
4. Turn power switch to ON. Adjust the tilt by using the tilt adjustment lock knob (Figure 2-1) until you obtain a comfortable viewing angle.
5. Adjust the interpupillary distance (Figure 2-1) by sliding the eyepieces together or apart so each eye can observe the entire field of view at the same time. The eyepieces adjust independently. If necessary, readjust the eye relief.

NOTE

The sharpest image will be observed only when the objective lens and both eyepieces are properly focused. The objective focus adjustment is used to focus on objects at varying distances. The diopter adjustment rings are used to focus your eyes (with or without glasses) on the image intensifier screen. These adjustments operate independently and must be made separately.

6. Fold the right eyecup over the eyepiece with your right thumb or forefinger to obstruct view through the right eyepiece. Rotate the left diopter adjustment ring for the clearest view on the image intensifier screen.
 7. Fold the left eyecup over the eyepiece with your left thumb or forefinger to obstruct view through the left eyepiece. Rotate the right diopter adjustment ring for the clearest view on the image intensifier screen.
- K. Adjust the eye relief distance by pressing the socket release button (see Figures 2-1) and sliding the PVS-7 fore or aft to obtain a full field of view of the image. Readjust the diopter rings for the best image.

NOTE

Any readjustment of eye relief requires readjustment of the diopter rings.

9. Adjust the objective lens focus (Figure 2-1) while observing an object until the sharpest image is obtained.

10. To flip up, place an open hand under the goggle, grasp the goggle and rotate up and rearward until the latch is firmly engaged (Figure 2-11).



Figure 2-11. Flip-up Helmet Mount

NOTE

The PVS-7 will be turned off automatically when flipped up. The PVS-7 will not turn on automatically when flipped down.

11. To flip down, grasp the goggle housing and rotate down and forward until the latch is firmly engaged.

12. Turn the switch to the RESET/OFF position, then to the ON position to resume viewing.

C. Hand-Held Operation**CAUTION**

OPERATE THE PVS-7 UNDER DARKENED CONDITIONS ONLY OR USE THE LENS CAP TO COVER THE OBJECTIVE LENS FOR DAYLIGHT CONDITIONS.

NOTE

When using the PVS-7 without a mounting device, make sure to place the neck cord around your neck.

1. Ensure that the batteries are installed per paragraph 2-6, B.
2. Turn the RESET/OFF-ON-IR/PULL switch to ON.
3. Adjust the interpupillary distance (Figure 2-1) by sliding the eyepieces together or apart so each eye can observe the entire field of view at the same time. The eyepieces adjust independently.

NOTE

The sharpest image will be observed only when the objective lens and both eyepieces are properly focused. The objective focus adjustment is used to focus on objects at varying distances. The diopter adjustment rings are used to focus your eyes (with or without glasses) on the image intensifier screen. These adjustments operate independently and must be made separately.

4. Hold the PVS-7 with your left hand and fold the left eyecup over the eyepiece with your left thumb or forefinger to obstruct view through the left eyepiece. Rotate the right diopter adjustment ring for the clearest view on the image intensifier screen.
5. Hold the PVS-7 with your right hand and fold the right eyecup over the eyepiece with your right thumb or forefinger to obstruct view through the right eyepiece. Rotate the left diopter adjustment ring for the clearest view on the image intensifier screen.
6. Readjust the objective lens assembly while observing an object until the sharpest image is obtained.

D. Operation with Compass Assembly

NOTE

The objective lens focus can be fine tuned after installation, but in order to obtain an accurate reading, the compass must be vertical. (The compass image must be level).

1. Install per paragraph 2-6, F.
2. If necessary, to more clearly view your distant object, adjust the objective focus slightly by gripping the compass and turning clockwise.
3. To view the compass through the PVS-7, grip the compass with index finger on top and thumb on illumination button on the bottom

(Figure 2-4). Press button slightly with thumb until proper brightness is obtained. The image should appear as shown in Figure 2-12.



Figure 2-12. View Through Installed Compass

NOTE

Increase brightness slowly: if brightness is increased too quickly, excessive brightness may burn a temporary image into the image intensifier. The goggle must be focused at or near infinite for proper compass operation.

4. The compass readings should change when you move your head from side to side. Rotate or tap compass slightly to ensure compass is operating correctly. Hold the PVS-7 in a level position to assure live rotation of the compass scale.

WARNING

THE COMPASS ILLUMINATOR CAN BE SEEN BY OTHERS USING NIGHT VISION DEVICES.

NOTE

The compass reading is the magnetic North, not true North. The compass reading is within 2° of correct absolute magnetic bearing. Compass readings with a mounted PVS-7 (head mount or helmet mount) can be up to ±15° of correct absolute, magnetic bearing. This occurs most in the East (90°) to West (270°) and less in the North (0°) to South (360°) reading. If the compass is inadvertently magnetized this could cause an additional 15° error.

5. The tick mark closest to the center of the lighted display is the compass bearing. The tick marks are in degrees, with longer marks every five degrees and bearing labels every 10 degrees.

E. Use of the 3X or 5X Magnifier Lens Assembly. The 3X or 5X magnifier lens assembly can be threaded directly into the 1X objective lens, with the light interference filter (LIF) and sacrificial window removed. It can also be threaded into the focus ring adapter and slipped on over the end of the objective lens with the LIF installed.

NOTE

The Neck cord can be used to tether the magnifier to your person to prevent losing the lens if it is dropped. To use the Neck cord, tie the end without the clip tightly around the magnifier and attach the clip to a buttonhole, belt loop or other convenient point.



Figure 2-13. PVS-7 with Magnifier Lens Assembly Installed

F. Infrared (IR) Operations

WARNING

THE IR ILLUMINATOR IS A LIGHT THAT IS INVISIBLE TO THE UNAIDED EYE FOR USE DURING CONDITIONS OF EXTREME DARKNESS. HOWEVER, THE LIGHT FROM THE ILLUMINATOR CAN BE DETECTED BY THE ENEMY USING NIGHT VISION DEVICES.

1. Pull the RESET/OFF-ON-IR/PULL switch knob (Figure 2-1) out and rotate clockwise to the IR position. With the PVS-7 held to the eyes, observe that a red light appears in the left eyepiece. This in-

dicates that the IR illuminator is operating. When spring loaded momentary IR position is used, the illuminator should only flash on.

2. To Operate with the IR Spot/Flood Lens: Pull the RESET/OFF-ON-IR/PULL switch knob out and rotate clock-wise to the IR position. With the PVS-7 held to the eyes, turn the IR spot/flood until you have achieved the optimum illumination of the desired distance. Turn the RESET/OFF-ON-IR/PULL switch counterclockwise to the ON position. Observe that the red indicator disappears.

2-9 PREPARATION FOR STOWAGE

A. Shutdown. Perform the following procedures to shut down the PVS-7.

1. Turn the RESET/OFF-ON-IR/PULL switch to the OFF position.
2. Remove the PVS-7 from the head mount or helmet mount (if so equipped) by depressing the latch lever (Figure 2-1) and removing the PVS-7 from the head mount socket.

B. Packaging After Use.

1. Unscrew the battery cap and remove the battery(ies).
2. Inspect the battery compartment for corrosion or moisture. Clean and dry if necessary.
3. Replace the battery cap.
4. Remove the demist shields, sacrificial window or compass assembly if installed. Install the lens cap.

NOTE

Prior to placing the PVS-7 assembly into the carrying case, ensure the goggle and case are free of dirt, dust and moisture.

5. Place demist shields, batteries, carrying case strap, lens paper, sacrificial window, manual, LIF, brow pads, head mount, helmet mount and compass into the carrying case (see Figure 1-1).
6. Place the PVS-7 (objective lens down) into the shallow pocket of the carrying case.
7. Place the carrying case into the shipping/storage case (Figure 2-14); close and latch it.

8. Return to storage area.

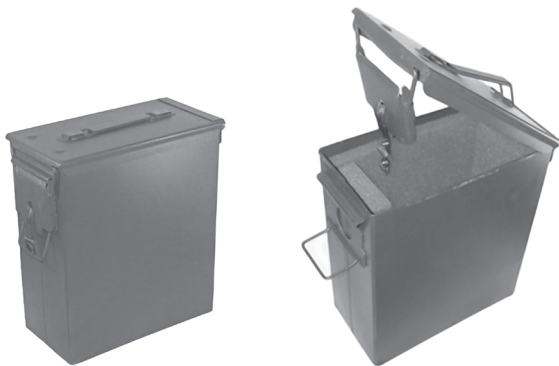

Figure 2 - 14. PVS-7 Shipping/storage case

CHAPTER 3

MAINTENANCE INSTRUCTIONS

SECTION I: TROUBLESHOOTING PROCEDURES

3-1 TROUBLESHOOTING

Table 3-1 lists common malfunctions that you may find with your equipment. Perform the tests, inspections and corrective actions in the order they appear in the table.

This table cannot list all the malfunctions that may occur, all the tests and inspections needed to find the fault, or all the corrective actions to correct the fault. If the equipment malfunction is not listed or actions listed do not correct the fault, notify your maintainer.

Table 3-1. Operator's Troubleshooting

MALFUNCTION	TEST / INSPECTION	CORRECTIVE ACTION
1. Goggle fails to activate	Visual	Turn switch to RESET/OFF position and then ON
	Check for defective, missing or improperly installed battery(ies)	Replace battery(ies) or install correctly If PVS-7 still fails to activate, refer to higher level of maintenance
2. IR indicator fails to activate	Visual	Refer to higher level of maintenance
3. Poor image quality	Check objective lens or eyepiece focus	Refocus
	Check for fogging or dirt on lens	Clean lens surface

MALFUNCTION	TEST /INSPECTION	CORRECTIVE ACTION
4. Light visible around eyecup	<p>Check eye relief distance</p> <p>Check eyecup for resiliency</p>	<p>Readjust for proper eye relief distance</p> <p>If eyecups defective, refer to higher level of maintenance</p>
5. Diopter adjustment cannot be made	Check to see if the diopter adjustment ring is bent or broken	If damaged, refer to higher level of maintenance
6. Interpupillary adjustment cannot be made (left & right eye)	Defective eyepiece assembly	Refer to higher level of maintenance
7. Battery cap difficult to turn	<p>Check for dirt or grit in threads</p> <p>Visually inspect for the presence of an o-ring</p> <p>Check for damaged battery cap or threads on battery compartment</p>	<p>Clean</p> <p>If o-ring is missing: refer to higher level of maintenance</p> <p>If damaged, refer to higher level of maintenance</p>
8. PVS-7 does not shut off when removed from head mount during operation	Visual	Return both the PVS-7 and head mount to higher level of maintenance

MALFUNCTION	TEST / INSPECTION	CORRECTIVE ACTION
9. Head straps cannot be tightened	Check for defective buckles, fasteners or straps	If damaged, refer to higher level of maintenance
10. Head mount or helmet mount socket and goggle do not catch	Check socket or latch for dirt Check socket or latch for damage	Clean socket and latch If damaged; return both head mount or helmet mount and PVS-7 to higher level of maintenance
11. Helmet mount will not tighten to helmet	Visual	If damaged, refer to higher level of maintenance
12. LIF will not thread in or obstructs view	Check for dirt in threads Check for damaged assembly	Clean threads If damaged, refer to higher level of maintenance
13. IR spot/flood lens will not adjust	Visual	Refer to higher level of maintenance
14. Compass does not illuminate	Visual	Refer to higher level of maintenance
15. Compass will not stay on the PVS-7	Visual	Possibly missing an o-ring Refer to higher level of maintenance

MALFUNCTION	TEST /INSPECTION	CORRECTIVE ACTION
16 Compass display is not clear	Visual	Make sure the PVS-7 is focused for infinity. If so and compass display is still not clear refer to higher level of maintenance
17. PVS-7 does not shut off when exposed to high light test under day light or bright room light.	<p>Perform the following tests under day light or bright room light</p> <p>Place the lens cap on the objective lens. Turn PVS-7 on and observe that they shut off within 70 (± 30) seconds after energized</p> <p>Turn goggle off and then on to re-energize</p>	If damaged, refer to higher level of maintenance

SECTION II: MAINTENANCE PROCEDURES

3-2. CLEANING THE PVS-7

CAUTION

THE PVS-7 IS A PRECISION ELECTRO-OPTICAL INSTRUMENT AND MUST BE HANDLED CAREFULLY. DO NOT SCRATCH THE EXTERNAL LENS SURFACES OR TOUCH THEM WITH YOUR FINGERS.

Clean the goggle with water if necessary and dry thoroughly. Clean lenses with lens paper (and water if necessary, except for demist shields).

CAUTION

WIPING DEMIST SHIELDS WITH LENS PAPER WHILE WET CAN DAMAGE THE COATING.

3-3. HEAD MOUNT MAINTENANCE

A. Brow Pad Replacement. Replace the brow pad when cracked, torn or contaminated. Perform the following procedure to remove and replace the brow pads.

CAUTION

FOR PROTECTION OF THE IMAGE INTENSIFIER, DISCONNECT THE PVS-7 FROM THE HEAD MOUNT PRIOR TO REPLACING BROW PADS.

1. Firmly grasp the head mount and remove the old brow pad.
2. Gently press on the new brow pad. Lightly smooth out any wrinkles in the new brow pad.

B. Neck Pad Re-installation. During operation of the goggle, it is possible for the neck pad to become separated from its position on the headband. Perform the following procedure to reinstall the neck pad.

1. Lift the upper headband strap retention tab (see Figure 3-1) allowing the neck pad strap to be inserted underneath.
2. Slip the neck pad strap all the way under the upper strap retention tab and then pull the lower part of the neck pad strap under the lower strap retention.

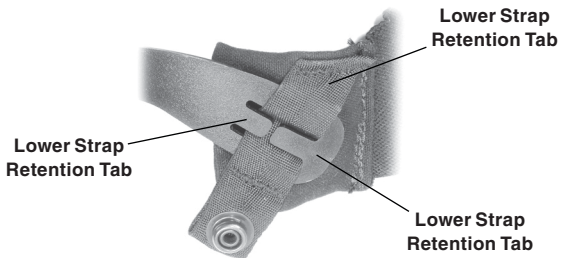

Figure 3-1. Re-installing the Neck Pad

3. Repeat steps 1 and 2 for the other side of the headband and neck pad if necessary.

C. Lacing the Sliding Bar Buckles. While donning and adjusting the head mount, it is possible for a strap to slip out of a slide fastener. Perform the following procedure to replace the strap and sliding bar buckle.

1. Thread the strap from the inside of the buckle over the moveable sliding bar (see Figure 3-2). Thread the strap back through the buckle but this time under the sliding bar and over the serrated part of the buckle.
2. Pull the strap through the buckle and tighten as necessary.
3. Repeat steps 1 and 2 for any other straps and buckles that may have come undone.

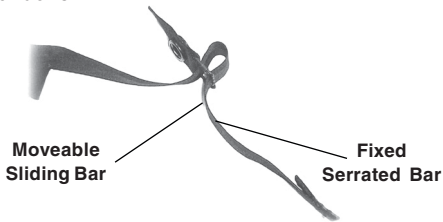

Figure 3-2. Lacing the Sliding Bar Buckles

APPENDIX A

SYSTEM OPTIONAL EQUIPMENT

Table A-1. System Optional Equipment

ITEM	DESCRIPTION	QUANT	PART NO
1	Helmet Mount Assy.	1	ATN3256390
2	Objective Filter Assy., LIF	1	ATN5009737
3	Sacrificial Window Assy.	1	ATN3144264
4	Demist Shield Assy.	2	ATN31442632
5	Case, Shipping/Storage	1	ATN3187393
6	Battery, Lithium	1	B-5567/U
7	3X A focal Lens Assy.	1	ATN5009717
8	Kit Adapter, 3X Afocal, 7D	1	ATN5009718
9	5X Afocal Lens Assy.	1	ATN5009719
10	Kit Adapter, 5X Afocal, 7D	1	ATN5009720
11	Obj. Lens., 3X, 7D	1	ATN5009721
12	Obj. Lens., 4X, 7D	1	ATN5009722
13	Obj. Lens., 6X, 7D	1	ATN5009723
14	Sacrificial Filter Assy., 75mm	1	ATN3144265
15	Sacrificial Filter Assy., 108mm	1	ATN3144266
16	Sacrificial Filter Assy., 162mm	1	ATN3144267
17	Lens Cover Assy., 75mm	1	ATN5009724
18	Lens Cover Assy., 108mm	1	ATN5009725
19	Lens Cover Assy., 162mm	1	ATN5009726
20	Tripod Adapter Assy., (4X/6X)	1	ATN3187394
21	Shipping Case Assy.	1	ATN3187395
22	Mount Assy., 7D-SPH-5CG	1	ATN3187396
23	Objective Lens Assy., 54mm	1	ATN5009710

FOR TECHNICAL INFORMATION

ATN CORP.

1341 San Mateo Avenue
South San Francisco, CA 94080

(800) 910-2862
(650) 989-5100 tel.
(650) 875-0129 fax

www.atncorp.com
info@atncorp.com

FOR NOTE



For customer service and technical support, please contact
American Technologies Network Corp.

North American Office

1341 San Mateo Avenue, South San Francisco, CA 94080
phone: 800-910-2862, 650-989-5100; fax: 650-875-0129

European Office

The following countries can use our toll free number:

00 800 9102-8620

Austria, France, Germany, Holland, Italy, Spain, Sweden, Switzerland

For other countries, please use

38 048-7770214 or 38 048-7770345

www.atncorp.com